

IMPREZA e-BOXER/XV e-BOXER

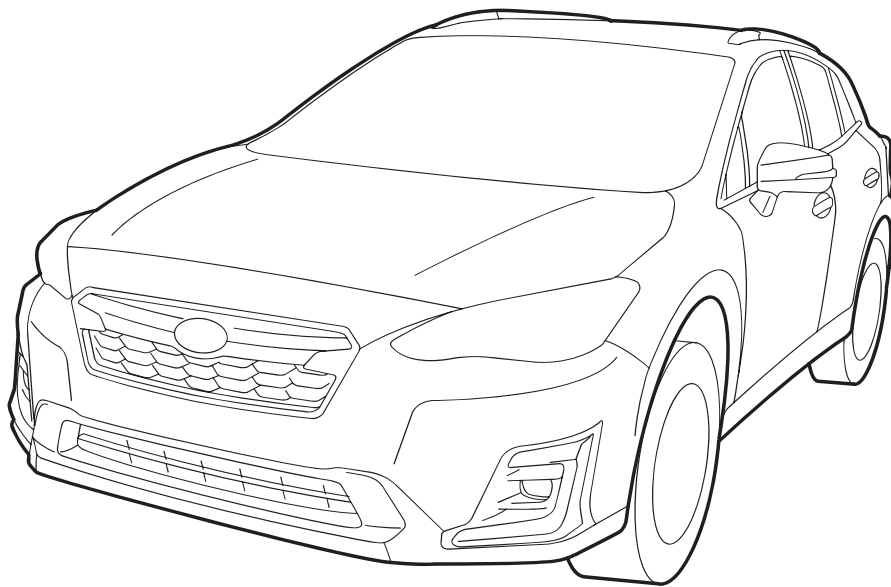

Emergency Response Guide



SUBARU

© 2020 SUBARU CORPORATION

All rights reserved. This document may not be altered without the written permission of SUBARU.

Publication No. V1400GE
Issued: February 2020

Foreword

SUBARU has prepared this Emergency Response Guide to educate and assist emergency responders in the safe handling of the Hybrid technology.

Except where noted in this guide, the basic vehicle system and features for the IMPREZA e-BOXER/XV e-BOXER are the same as those on the conventional, non-hybrid IMPREZA/XV.

High voltage electricity powers the drive motor, electric oil pump, drive motor inverter, electric oil pump inverter and DC/DC converter. All other automotive electrical devices such as the headlights, radio, and gauges are powered from a separate 12 Volt auxiliary battery. Numerous safeguards have been designed into the IMPREZA e-BOXER/XV e-BOXER to help ensure the high voltage, approximately 118.4 Volt, Lithium-ion (Li-ion) battery is kept safe and secure in an accident.

The IMPREZA e-BOXER/XV e-BOXER utilizes the following electrical systems:

- Nominal 118.4 Volts DC
- Nominal 12 Volts DC

IMPREZA e-BOXER/XV e-BOXER Features:

- A high voltage battery rated at 118.4 Volts.
- A high voltage motor driven drive motor rated at 118.4 Volts.
- A high voltage motor driven electric oil pump rated at 118.4 Volts.
- A body electrical system rated at 12 Volts, negative chassis ground.
- Supplemental Restraint System (SRS) - frontal airbags, a driver knee airbag, front seat side airbags, side curtain airbags, seatbelt pretensioners and rear seatbelt pretensioners.

High voltage electrical safety remains an important factor in the emergency handling of the IMPREZA e-BOXER/XV e-BOXER. It is important to recognize and understand the disabling procedures and warnings throughout this guide.

Additional topics in this guide include:

- IMPREZA e-BOXER/XV e-BOXER identification.
- Hybrid system component locations and descriptions.
- Extrication, fire, recovery, and additional emergency response information.
- Roadside assistance information.

▼ IMPREZA e-BOXER/XV e-BOXER

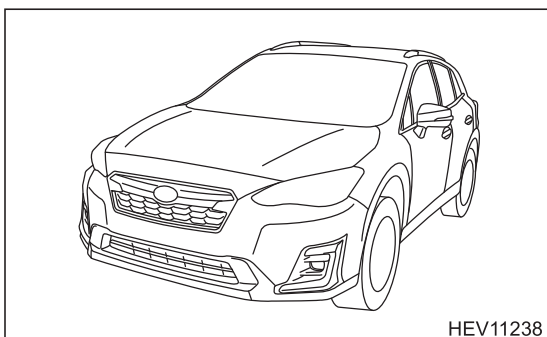

This guide is intended to assist emergency responders in the safe handling of a IMPREZA e-BOXER/XV e-BOXER vehicle during an incident.

Table of Contents

	Page
About the IMPREZA e-BOXER/XV e-BOXER	1
IMPREZA e-BOXER/XV e-BOXER Identification	2
Hybrid System Component Locations & Descriptions	7
Keys and Doors	11
Hybrid System Operation	21
High Voltage Battery	23
Low Voltage Batteries	25
High Voltage Safety	27
SRS Airbags & Seatbelt Pretensioners	29
Emergency Response	34
Extrication	34
Fire	53
Overhaul	54
Spills	56
First Aid	57
Submersion	58
Roadside Assistance	59

About the IMPREZA e-BOXER/XV e-BOXER

The IMPREZA e-BOXER/XV e-BOXER is the gasoline-electric hybrid vehicle for SUBARU. There are two hybrid power sources on board the vehicle:

1. Gasoline stored in the fuel tank for the gasoline engine.
2. Electricity stored in a high voltage battery for the drive motor.

The result of combining these two power sources is improved fuel economy and reduced emissions. The gasoline engine also powers a drive motor to charge the high voltage battery; unlike a pure all electric vehicle, the IMPREZA e-BOXER/XV e-BOXER never needs to be charged from an external electric power source.

Depending on the driving conditions one or both sources are used to power the vehicle. The following information explains how the IMPREZA e-BOXER/XV e-BOXER operates in various driving modes.

- (1) During light acceleration at low speeds, the vehicle is powered by the drive motor. The gasoline engine is shut off.
- (2) During normal driving, the vehicle is powered mainly by the gasoline engine. The gasoline engine also powers the drive motor to charge the high voltage battery.
- (3) During full acceleration, such as climbing a hill, both the gasoline engine and the drive motor power the vehicle.
- (4) During deceleration, such as when braking, the vehicle regenerates kinetic energy from the wheels to produce electricity that charges the high voltage battery.
- (5) While the vehicle is stopped, the gasoline engine and drive motor may be off, however the system remains on and operational.

Note:

While the vehicle is stopped, the gasoline engine may restart depending on conditions.

IMPREZA e-BOXER/XV e-BOXER Identification

In appearance, the IMPREZA e-BOXER/XV e-BOXER is nearly identical to the conventional, non-hybrid SUBARU IMPREZA/XV. The IMPREZA e-BOXER/XV e-BOXER is a 5-door Sports Utility Vehicle (SUV). Exterior, interior, and engine compartment illustrations are provided to assist in identification.

The alphanumeric 17 character Vehicle Identification Number (VIN) is provided in the front windshield and passenger side floor. (Left-hand drive models)

The alphanumeric 17 character Vehicle Identification Number (VIN) is provided in the front windshield and driver side floor. (Right-hand drive models)

Example VIN: **JF1GTE**-XXXXXX

IMPREZA e-BOXER/XV e-BOXER is identified by the first 6 alphanumeric characters **JF1GTE**.

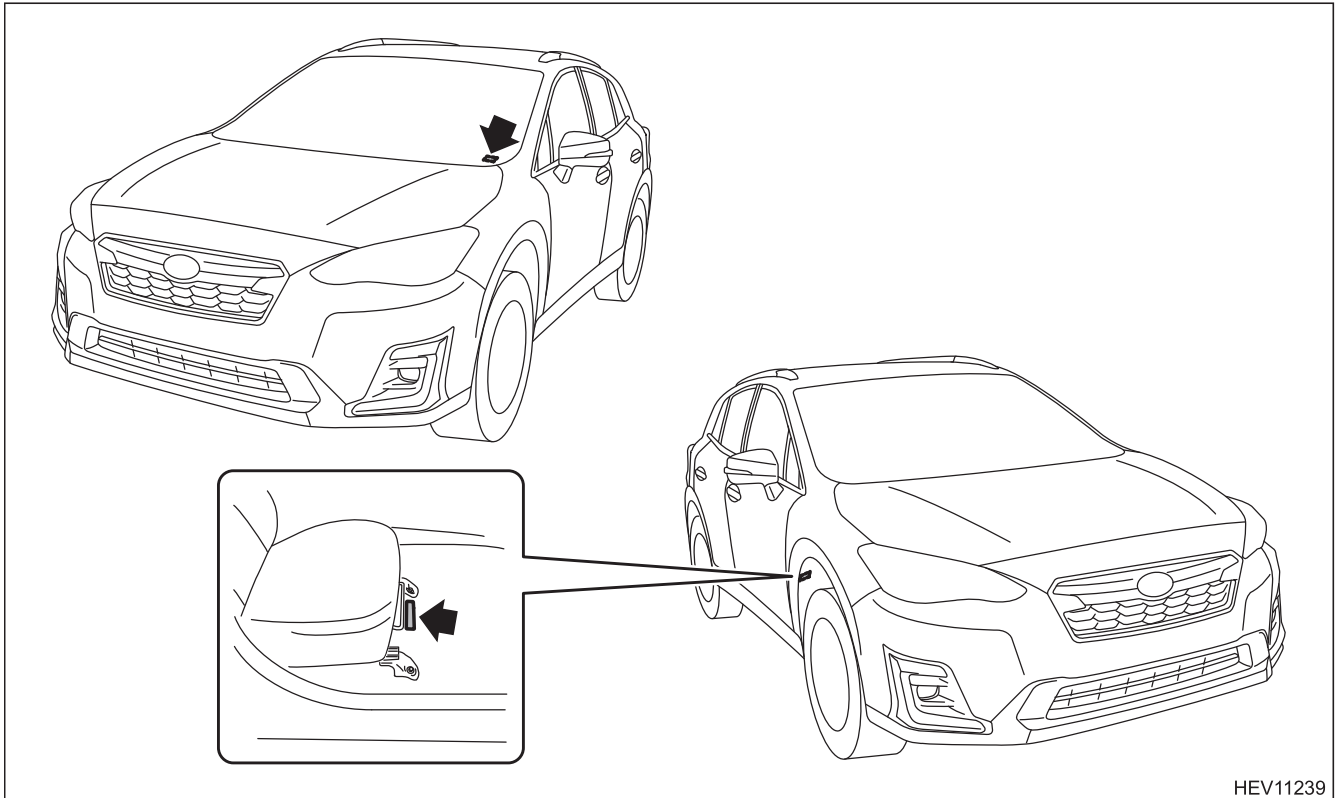

HEV11239

IMPREZA e-BOXER/XV e-BOXER Identification (Continued)

Exterior

- ① **e-BOXER** logo on each front fender.
- ② **e-BOXER** logo on the right side of the rear gate.

▼ Exterior Front and Rear View

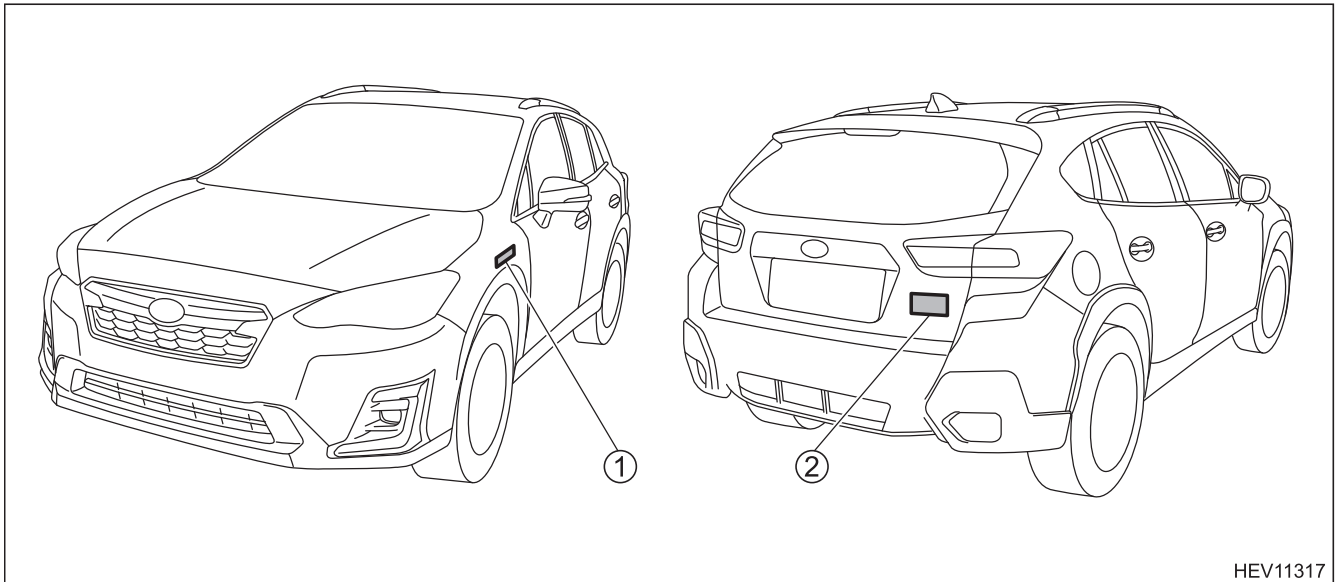

HEV11317

Interior

- ③ Combination meter (HYBRID system READY indicator light) located in the dash behind the steering wheel.

▼ Interior View

- Left-hand drive models

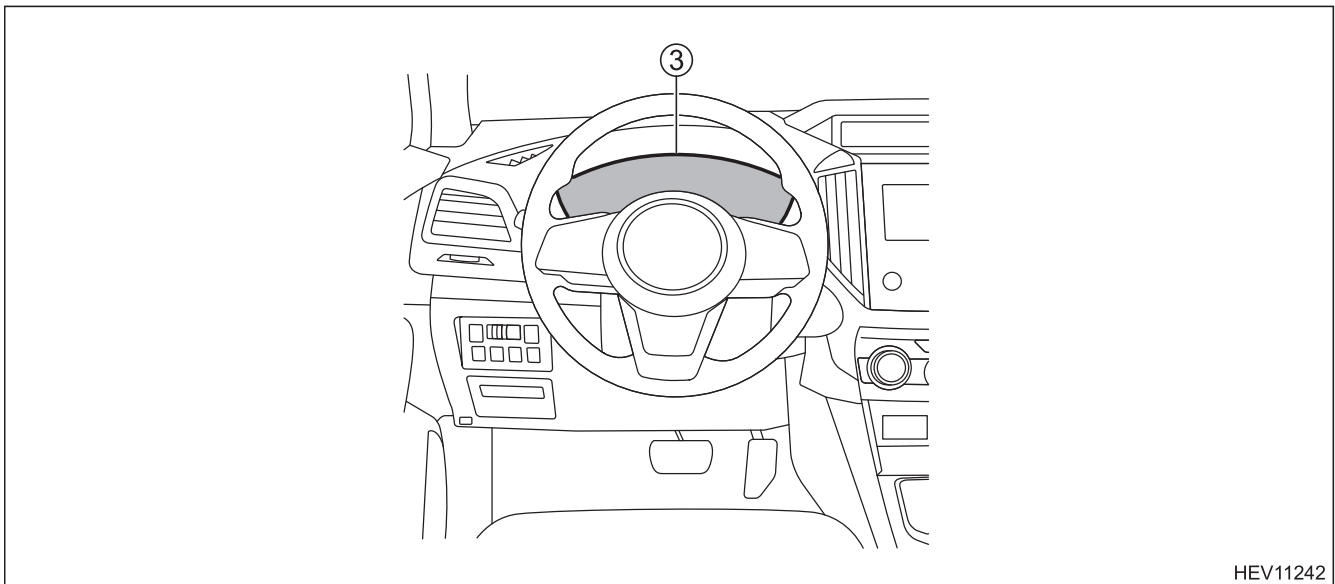

- Right-hand drive models

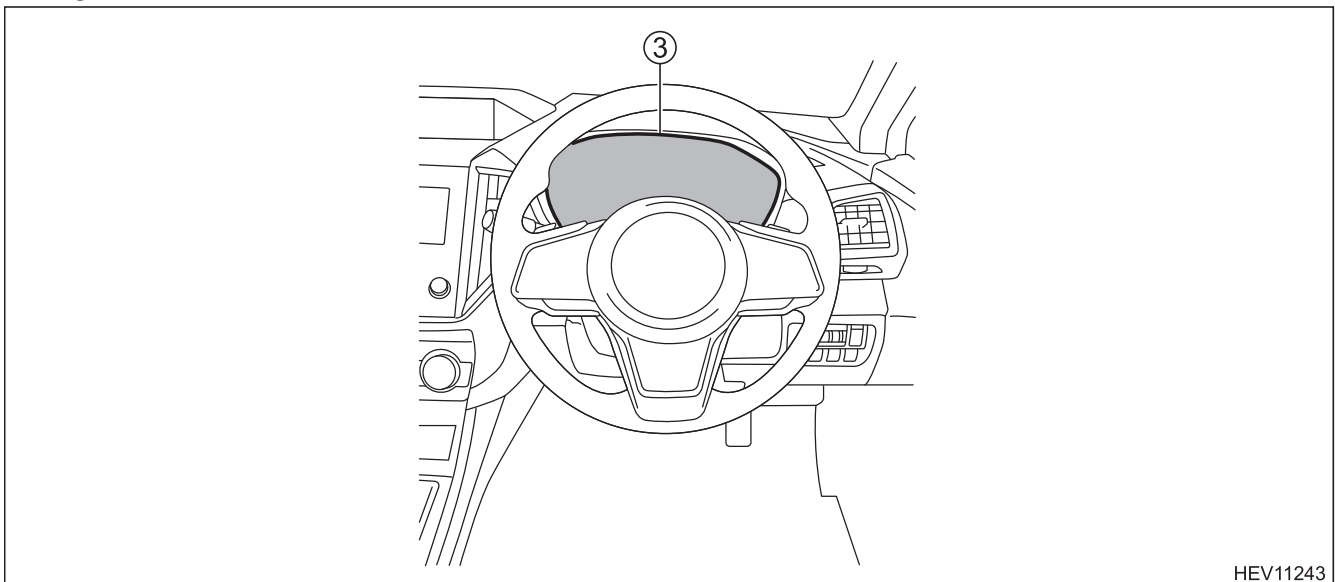

IMPREZA e-BOXER/XV e-BOXER Identification (Continued)

- ④ HYBRID system READY indicator light

▼ Combination Meter

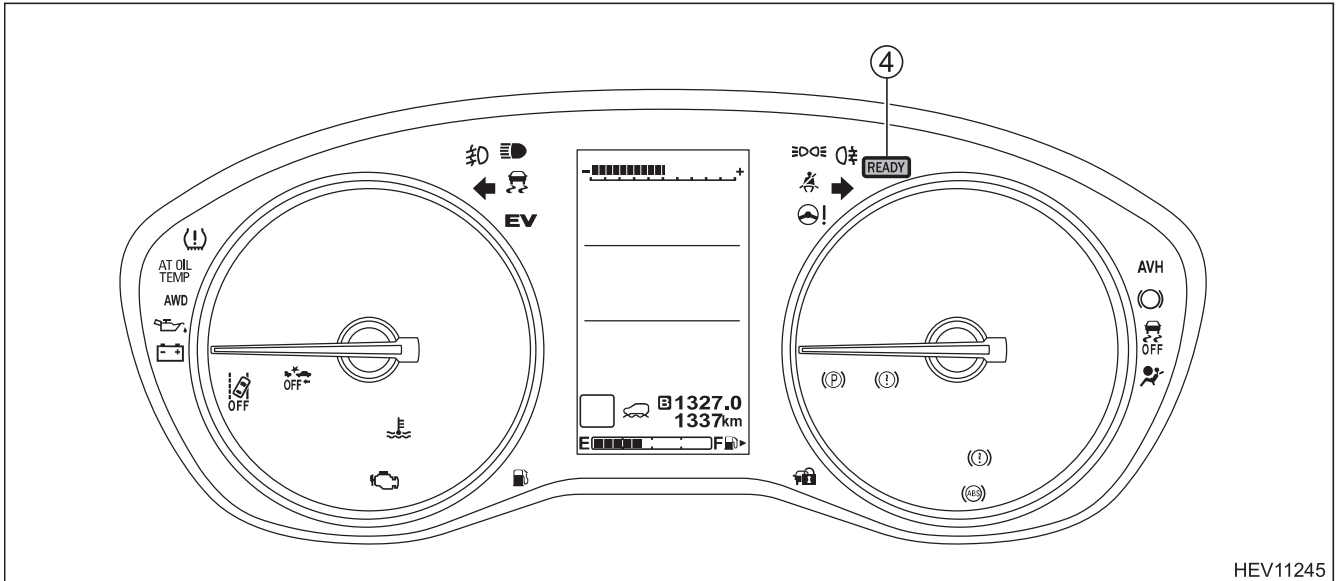

The illustration above is a typical example. For some models, the combination meter may be slightly different than that shown in the illustration.

Engine Compartment

- ⑤ 12 Volt engine restart battery.
- ⑥ 2.0-liter aluminum alloy gasoline engine.
- ⑦ 12 Volt auxiliary battery.

▼ Engine Compartment View

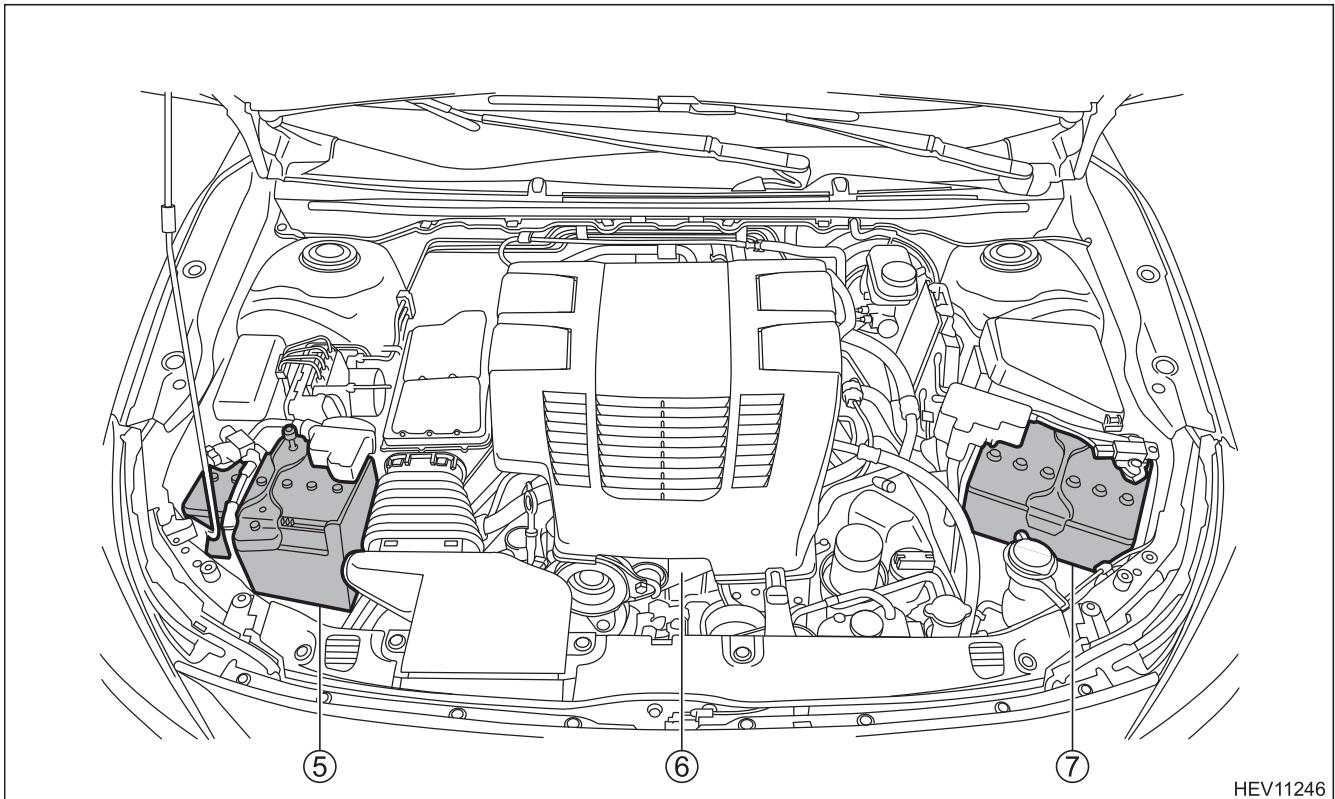

HEV11246

Hybrid System Component Locations & Descriptions

Component	Location	Description
① 12 Volt Auxiliary Battery	Engine Compartment	A lead-acid battery that supplies power to the low voltage devices.
② 12 Volt Engine Restart Battery	Engine Compartment	A lead-acid battery that supplies power to the integrated starter generator.
③ High Voltage Battery	Cargo Area, Mounted to Cross Member behind Rear Seat	118.4 volt Lithium-ion battery is composed of 32 battery cells that are series-connected.
④ Power Cables	Undercarriage, Engine Compartment and Cargo Area	Orange colored power cables carry the 3-phase Alternating Current (AC) between the drive motor inverter, electric oil pump inverter, drive motor, and electric oil pump. This cable also carries 12 Volt DC between the DC/DC converter and 12 Volt auxiliary battery.

▼ Components (Top View) and Power Cables

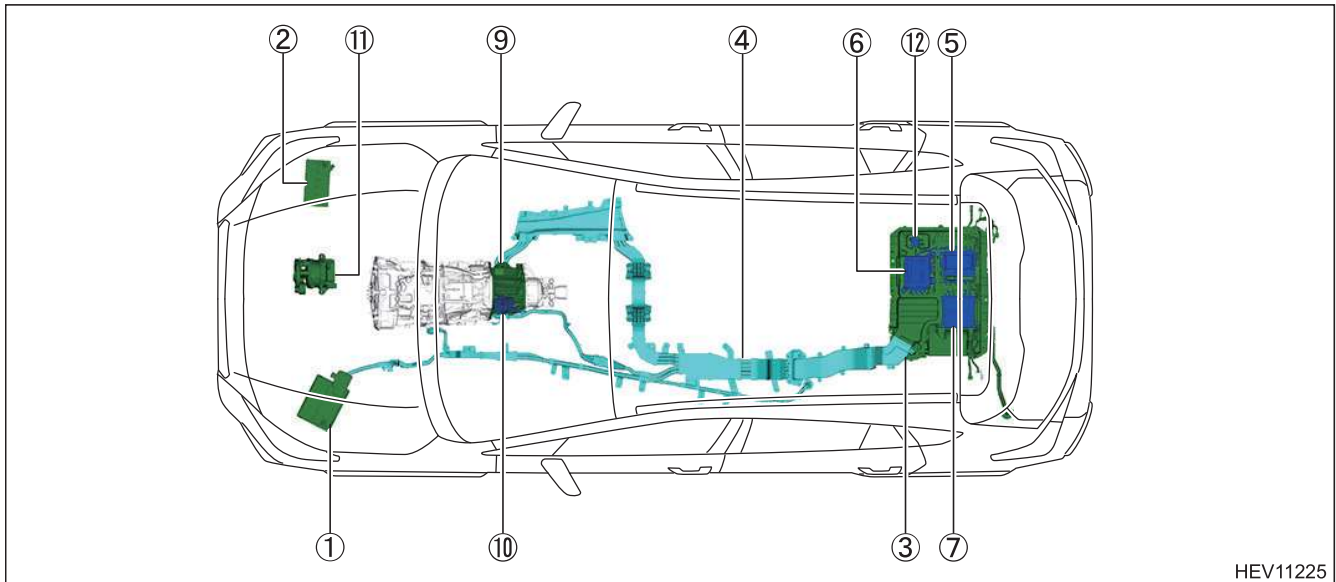

HEV11225

Hybrid System Component Locations & Descriptions (Continued)

Component	Location	Description
⑤ Drive Motor Inverter	Cargo Area	Inverts the high voltage electricity from the high voltage battery to 3-phase AC electricity that drives the drive motor.
⑥ Electric Oil Pump Inverter	Cargo Area	Inverts the high voltage electricity from the high voltage battery to 3-phase AC electricity that drives the electric oil pump.
⑦ DC/DC Converter	Cargo Area	Convert high voltage electricity from the high voltage battery to 12 Volt electricity that charges the 12 Volt auxiliary battery.
⑧ Gasoline Engine	Engine Compartment	Provides two functions: 1) Powers vehicle. 2) Powers drive motor to charge the high voltage battery. The engine is started and stopped under control of the vehicle computer.
⑨ Drive Motor	Contained in the rear part of transmission	3-phase high voltage AC permanent magnet electric motor contained in the transmission. It is used to power all wheels. The drive motor also charges the high voltage battery.

▼ Hybrid System Components

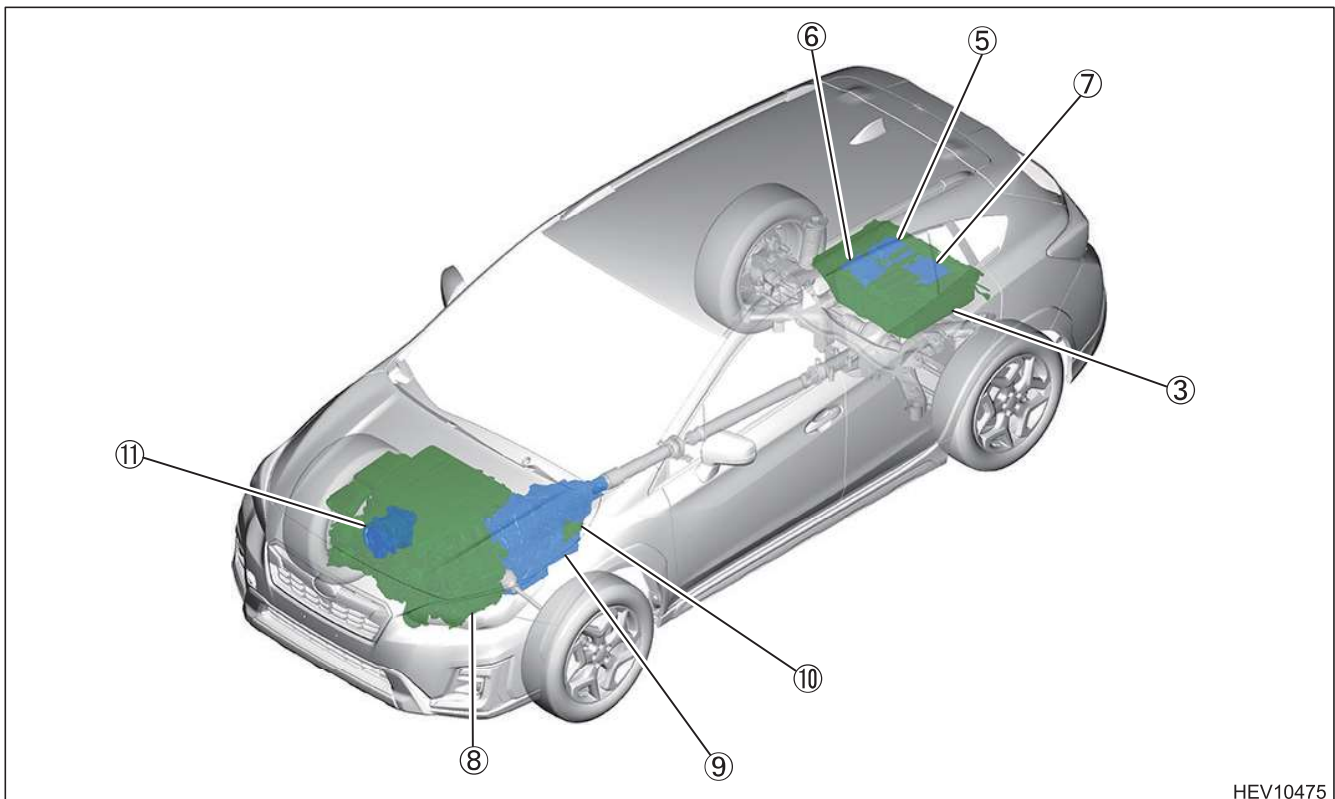

HEV10475

Hybrid System Component Locations & Descriptions (Continued)

Component	Location	Description
⑩ Electric Oil Pump	Located on the left side of the transmission	The electric oil pump is powered by the high voltage battery. It maintains the oil pressure of the transmission.
⑪ Integrated Starter Generator	Engine Compartment	Combines the function of the alternator and the starter. It will restart the engine, during auto start stop mode or EV driving mode.
⑫ Service Disconnect Plug	Cargo Area, located on the right side of the high voltage battery	Used to disable the high voltage system.
⑬ Fuel Tank and Fuel Line	Undercarriage and right side in cabin	The fuel tank provides gasoline via a fuel line to the engine. The fuel line is routed right side in cabin.

▼ Fuel Tank and Fuel Line

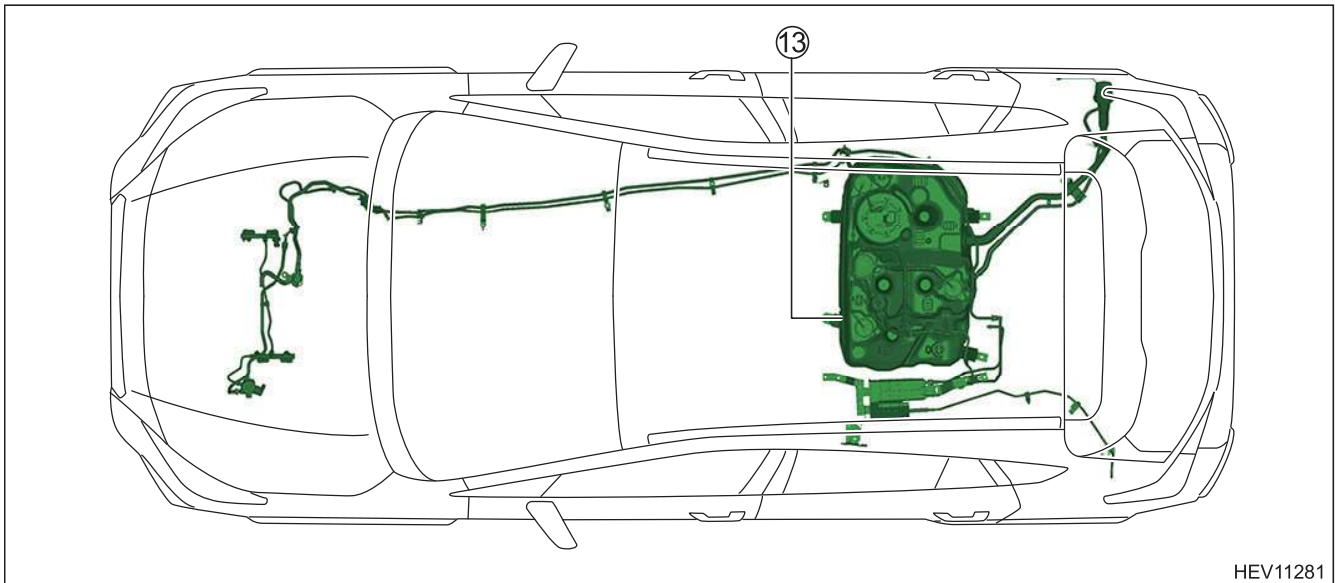

HEV11281

Hybrid System Component Locations & Descriptions (Continued)

Key Specifications

Gasoline Engine : 110 kw (150 PS), 2.0-liter Aluminum Alloy Engine

Electric Motor : 12.3 kw (16.7 PS), Permanent Magnet Synchronous Motor

Transmission : Automatic Only (continuously variable transmission)

HV Battery : 118.4 Volt Sealed Li-ion Battery

Curb Weight : 1,514 - 1,576 kg/3,338 - 3,475 lbs

Fuel Tank : 48.0 liters/12.7 gals

Frame Material : Steel Unibody

Body Material : Steel Panels except for Aluminum Hood

Seating Capacity : 5 passenger

▼ Steel Unibody

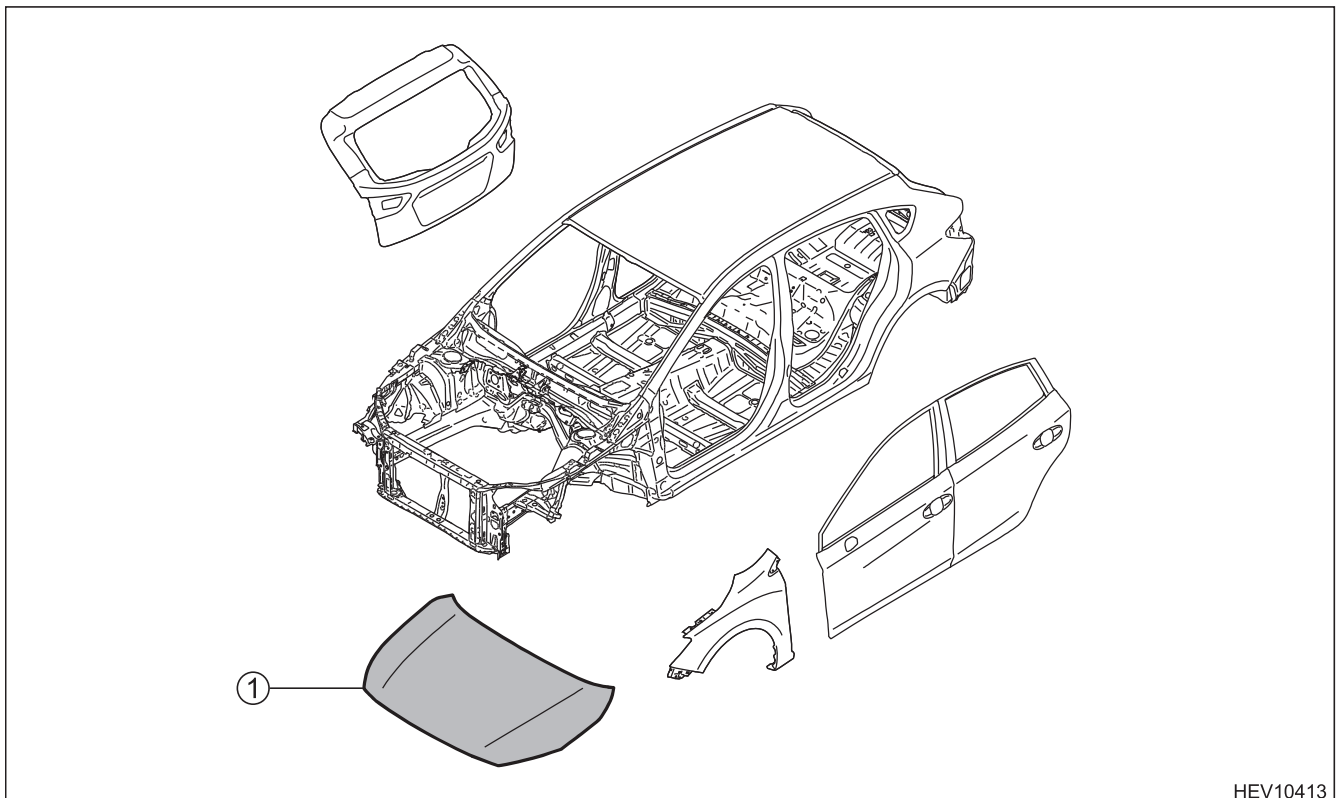

① Aluminum Hood

Keys and Doors

Keyless Access with Push-button Start System (Optional Equipment)

The keyless access with push-button start system allows you to perform the following functions when you are carrying the access key fob.

- Locking and unlocking of the doors and rear gate.
 - Starting and stopping the hybrid system.
- Locking and unlocking by the remote keyless entry system can also be controlled with the buttons on the access key fob.

While pressing the release button of the access key fob, take out the emergency key. The emergency key is used for locking and unlocking the driver's door.

▼ Access Key Fob

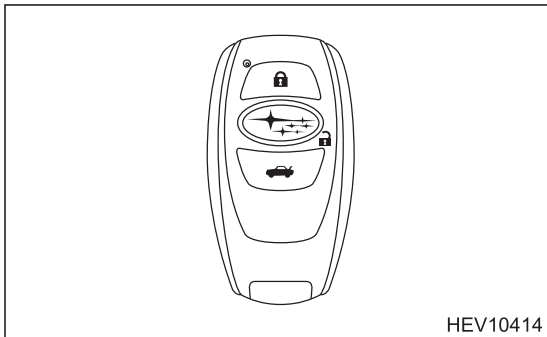

▼ Emergency Key

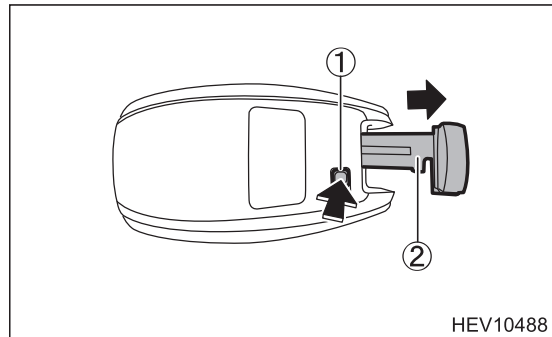

① Release Button

② Emergency Key

■ Operating Ranges

The operating ranges of the door and rear gate locking/unlocking functions are approximately 40 to 80 cm (16 to 32 in) from the respective door handles and the rear gate ornament.

When the access key fob is within either of the operating ranges of the front doors, the LED indicator on the access key fob flashes. When the keyless access functions are disabled, the LED indicator does not flash unless a button on the access key fob is pressed.

Note:

- If the access key fob is placed too close to the vehicle body, the keyless access function may not operate properly. If it does not operate properly, repeat the operation from further away.
- If the access key fob is placed near the ground or in an elevated location from the ground, even if it is in the indicated operating range, the keyless access function may not operate properly.
- When the access key fob is within the operating range, it is possible for anyone, even someone who is not carrying the access key fob, to operate the keyless access function. Note that locking and unlocking can be operated only by the door handle, door lock sensor, rear gate opener button or rear lock button in the operating range in which the access key fob is detected.
- It is not possible to lock the doors and rear gate using the keyless access function when the access key fob is inside the vehicle. However, depending on the status of the access key fob and the environmental conditions, the access key fob may be locked inside the vehicle. Before locking, make sure that you have the access key fob.
- When the battery of the access key fob is discharged, or when operating it in a location with strong radio waves or noise (e.g., near a radio tower, power plant, broadcast station, large display, airport, electrical sign board or an area where wireless equipment is used), or while talking on a cell phone, the operating ranges may be reduced, or the keyless access function may not operate.
- The doors may lock or unlock when the car is being washed or exposed to significant amount of water contacting the door handle while the access key fob is still in the operating range.

▼ Operating Ranges

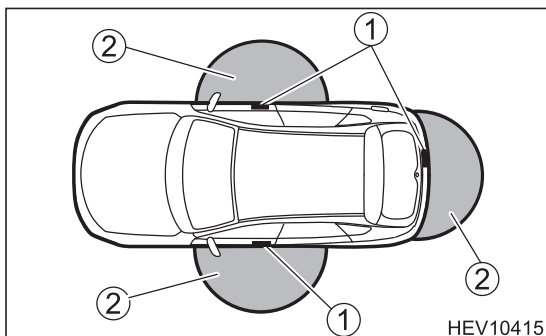

① Antenna

② Operating Range

▼ LED Indicator

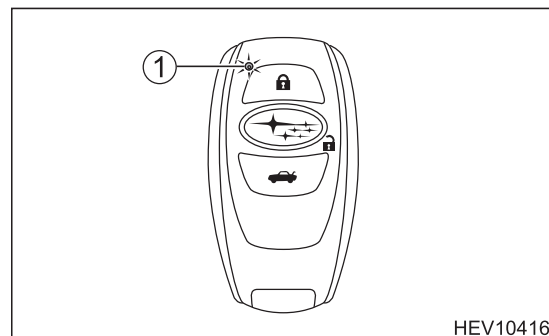

① LED Indicator

■ Unlocking

Carry the access key fob, and grip the door handle.

- **Models without double locking system:**

All doors and the rear gate will be unlocked.

Also, the hazard warning flashers will flash twice.

The described operation is the default setting.

It can be selected by either unlocking just the driver's door, or all doors and the rear gate.

- **Models with double locking system:**

- The driver's door handle:

Only the driver's door will be unlocked.

- The front passenger's door handle:

All doors and the rear gate will be unlocked.

Also, the hazard warning flashers will flash twice.

The described operation is the default setting.

It can be selected by either unlocking just the driver's door, or all doors and the rear gate.

■ Opening Rear Gate

Carry the access key fob, and press the rear gate opener button.

- **Models without double locking system:**

The rear gate and all doors will be unlocked, and the rear gate will be opened.

Also, the hazard warning flashers will flash twice.

The described operation is the default setting.

It can be selected by either unlocking just the rear gate, or all doors and the rear gate.

- **Models with double locking system:**

Only the rear gate will unlock and open.

Also, the hazard warning flashers will flash twice.

The described operation is the default setting.

It can be selected by either unlocking just the rear gate, or all doors and the rear gate.

▼ Unlocking

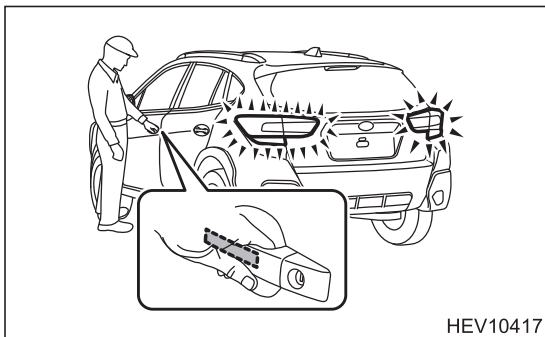

▼ Opening Rear Gate

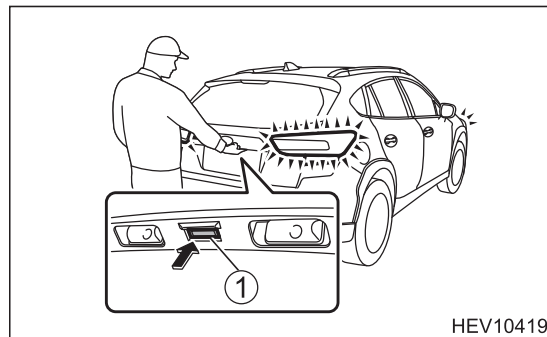

① Rear Gate Opener Button

Keys and Doors (Continued)

■ Locking with the Door Lock Sensor

Carry the access key fob, close all doors including the rear gate and touch the door lock sensor on the door handle. All doors including the rear gate will be locked. Also, the hazard warning flashers will flash once.

■ Locking with the Rear Lock Button

Carry the access key fob, close all doors including the rear gate and press the rear lock button. The rear gate and all doors will be locked. Also, the hazard warning flashers will flash once.

▼ Locking with the Door Lock Sensor

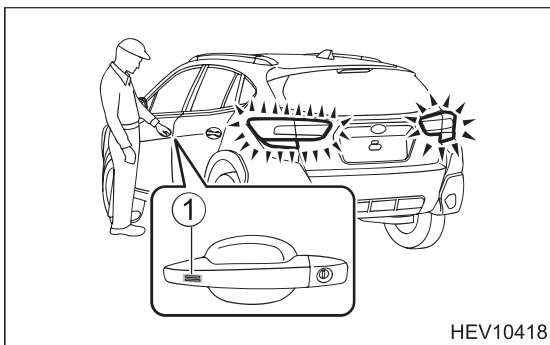

HEV10418

① Door Lock Sensor

▼ Locking with the Rear Lock Button

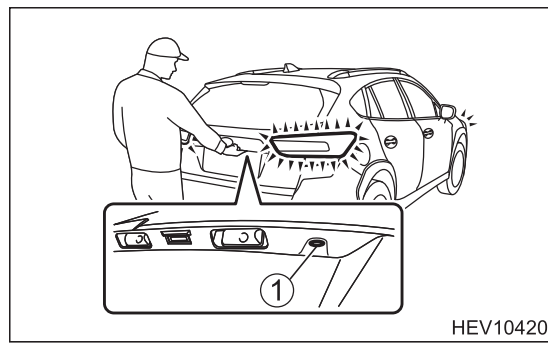

HEV10420

① Rear Lock Button

■ Vehicle Starting/Stopping

The access key fob has replaced the conventional emergency key, and the push-button ignition switch with operation indicator has replaced the ignition switch.

The access key fob only needs to be in proximity to the vehicle to allow the system to function.

- With the brake pedal released, the first push of the push-button ignition switch operates the "ACC" position, the second push operates the "ON" position, and the third push turns it OFF again.

Power Status Sequence (brake pedal released):

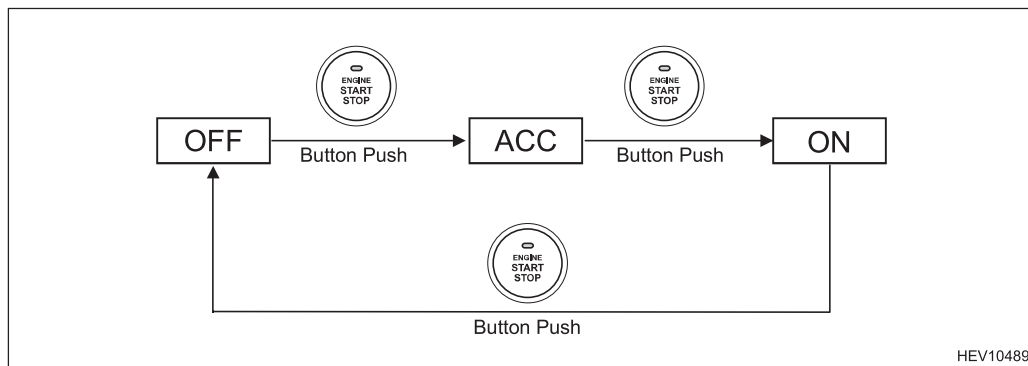

- Starting the vehicle takes priority over all other ignition modes. When the push-button ignition switch is pushed once while depressing the brake pedal, the engine will start. Starting the engine starts the hybrid system. To verify the vehicle has started, check that the operation indicator is off and the HYBRID system READY indicator light is illuminated in the combination meter.
- If the internal access key fob battery is dead, use the following method to start the vehicle.
 1. Hold the access key fob with the buttons facing you, and touch the push-button ignition switch with it.
 2. When the communication between the access key fob and the vehicle is completed, a chime (ding) will sound. At the same time, the status of the push-button ignition switch changes to either of the following.
 - When the keyless access with push-button start system is deactivated: "ACC"
 - Under other conditions: "ON"
- Once the vehicle has started and is on and operational (HYBRID system READY indicator light-ON), the vehicle is shut off by bringing the vehicle to a complete stop and then depressing the push-button ignition switch once.
- To shut off the vehicle before coming to a stop in an emergency, performing any one of the following two procedures:
 - The push-button ignition switch is pressed and held for 3 seconds or longer.
 - The push-button ignition switch is pressed briefly 3 times or more in succession. These procedures may be useful at an accident scene in which the HYBRID system READY indicator light is on, Park position cannot be selected, and the wheels remain in motion.

Keys and Doors (Continued)

Power status	Operation Indicator color	Operation
OFF	Turned off	Power is turned off.
ACC	Orange	The following systems can be used: Audio and accessory power outlet.
ON	Orange (while hybrid system is stopped)	All electrical systems can be used.
	Turned off (while hybrid system is running)	

▼ Push-button Ignition Switch with Operation Indicator

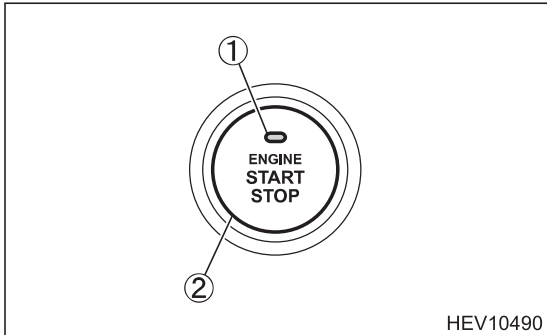

- ① Operation Indicator
- ② Push-button Ignition Switch

▼ Power Status Sequence (Brake Pedal Released)

- Left-hand drive models

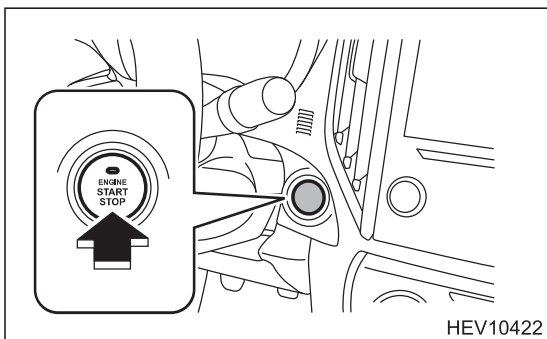

- Right-hand drive models

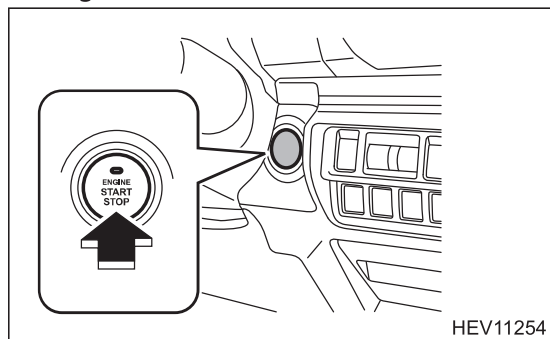

Keys and Doors (Continued)

▼ Starting Sequence (Brake Pedal Depressed)

- Left-hand drive models

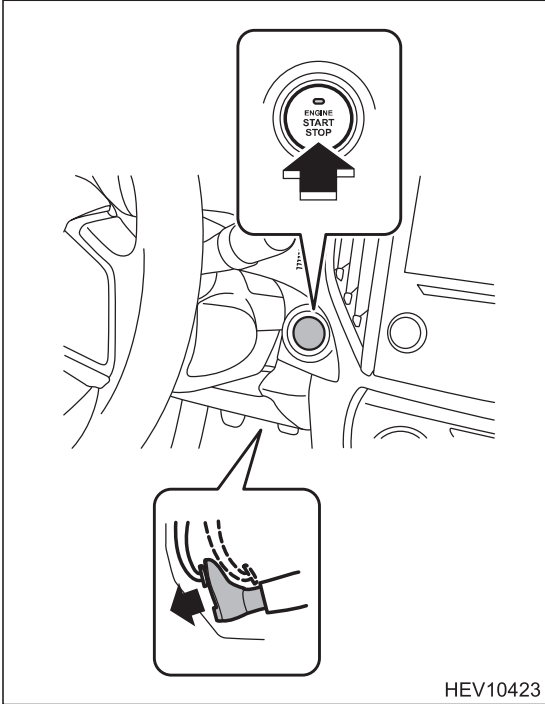

- Right-hand drive models

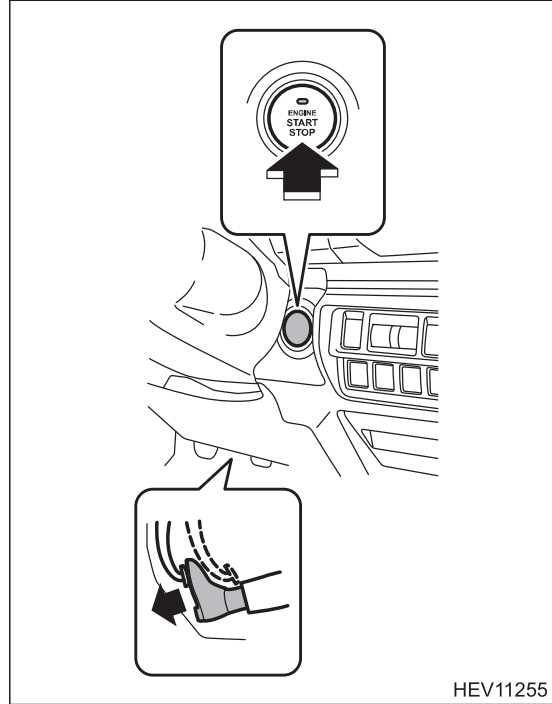

▼ Access Key Fob Recognition (When Access Key Fob Battery is Dead)

- Left-hand drive models

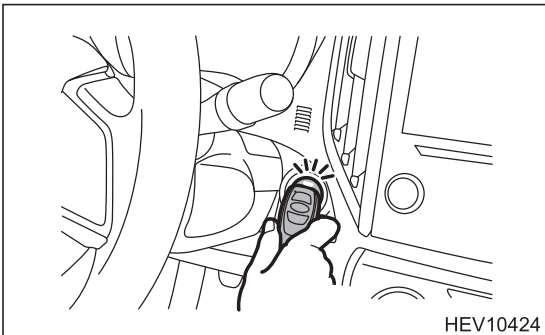

- Right-hand drive models

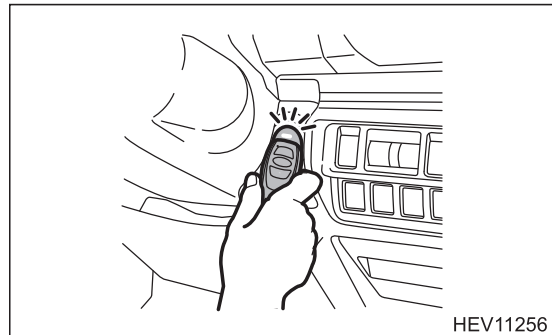

Remote Keyless Entry System

■ Transmitter

The remote transmitter can be used within a distance of approximately 10 m (33 ft) of the vehicle. The remote keyless entry system locks and unlocks all doors including the rear gate.

The system's operable distance will be shorter in areas near a facility or electronic equipment emitting strong radio waves such as a power plant, broadcast station, TV tower, or remote controller of home electronic appliances.

Note:

- Before leaving the vehicle, make sure that the doors are locked.
- The remote keyless entry system does not operate when the key is inserted in the ignition switch, when a push-button type ignition switch is set to a position other than "OFF" or when any of the doors or rear gate are not fully closed.
- For models with "keyless access with push-button start system", when the lock button on the access key fob is pressed while the access key fob is placed too close to the vehicle body, unlocking by the keyless access functions may not work. In such a case, the functions will recover by unlocking using the remote keyless entry system.

■ Locking the Doors

Pressing the lock button on the access key fob/transmitter locks all doors and the rear gate.

Note:

- If any of the doors (or the rear gate) is not fully closed, the hazard warning flashers will flash five times (the outside warning chime also sounds five times for models with "keyless access with push-button start system") to alert you that the doors (or the rear gate) are not properly closed.
- For models with "keyless access with push-button start system", the front door will be unlocked if you grip the front door handle while an access key fob is in the operating range. Pull the rear door handle to make sure that the doors have been locked.

■ Unlocking the Doors

Press the unlock button on the access key fob/transmitter near the vehicle.

▼ Models without double locking system

- **Models without door unlock selection function:**

All doors and the rear gate will be unlocked.
Also, the hazard warning flashers will flash twice.

- **Models with door unlock selection function:**

Note:

For security reasons, confirm the setting is set as “operational” or “nonoperational”.
The door unlock selection function makes it possible to unlock the driver’s door without unlocking any other doors.

- **Operational:**

Only the driver’s door will be unlocked. If you press the unlock button again within 5 seconds of unlocking the driver’s door, all of the other doors and the rear gate will be unlocked.

- **Non-operational:**

All doors and the rear gate are unlocked.

▼ Models with double locking system

1. Only the driver’s door will be unlocked.

Also, the hazard warning flashers will flash twice.

2. If you press the unlock button again within 5 seconds of unlocking the driver’s door, all of the other doors and the rear gate will be unlocked.

■ Unlocking the Rear Gate

Press the rear gate unlock button to unlock the rear gate.

The hazard warning flashers will flash twice.

▼ Access Key Fob

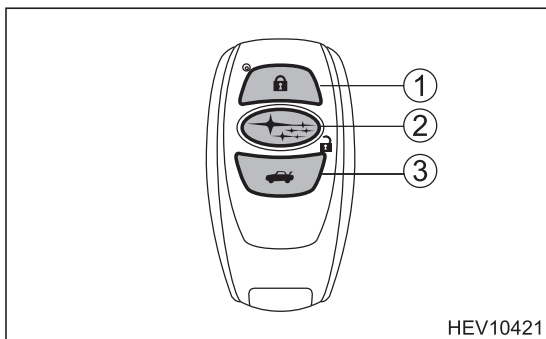

① Lock button
② Unlock button

③ Rear gate unlock button

▼ Remote Transmitter

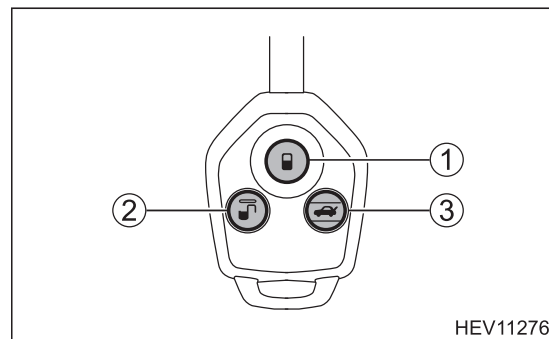

① Lock button
② Unlock button

③ Rear gate unlock button

Door Locks

■ Locking and Unlocking from the outside

▼ How to lock and unlock the vehicle by using the key

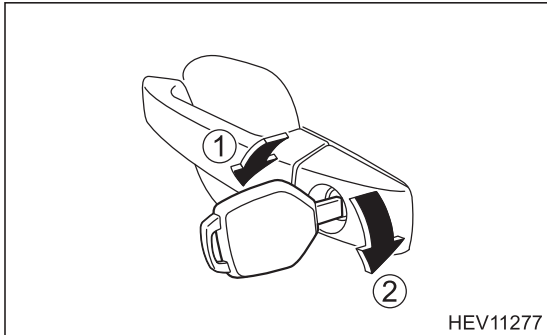

- ① Rotate the key toward the front to lock
- ② Rotate the key toward the rear to unlock

Note:

- The emergency key (models with an access key fob) is directional. If the key cannot be inserted, change the direction that the grooved side is facing and insert it again.
- **Models without a double locking system:**
 - To lock all doors including the rear gate, lock any door other than the driver's door from the inside of the vehicle, and then lock the driver's door.
 - To lock the driver's door from the outside with the key, turn the key toward the front.
 - To unlock the door, turn the key toward the rear.
- **Models with a double locking system:**
 - To lock the doors and the rear gate from the outside with the key, turn the key toward the front.
 - To unlock the doors and the rear gate, turn the key toward the rear.

Hybrid System Operation

Once the HYBRID system READY indicator light is illuminated in the combination meter, the vehicle may be driven. However, the gasoline engine does not idle like a typical automobile and will start and stop automatically. It is important to recognize and understand the HYBRID system READY indicator light provided in the combination meter. When lit, it informs the driver that the vehicle is on and operational even though the gasoline engine may be off and the engine compartment is silent.

Vehicle Operation

- With the IMPREZA e-BOXER/XV e-BOXER, the gasoline engine may stop and start at any time while the HYBRID system READY indicator light is on.
- Never assume that the vehicle is shut off just because the engine is off. Always look for the HYBRID system READY indicator light status. The vehicle is shut off when the HYBRID system READY indicator light is off.
- The vehicle may be powered by:
 1. The drive motor only.
 2. The gasoline engine only.
 3. A combination of both the drive motor and the gasoline engine.

▼ Combination Meter HYBRID system READY indicator light

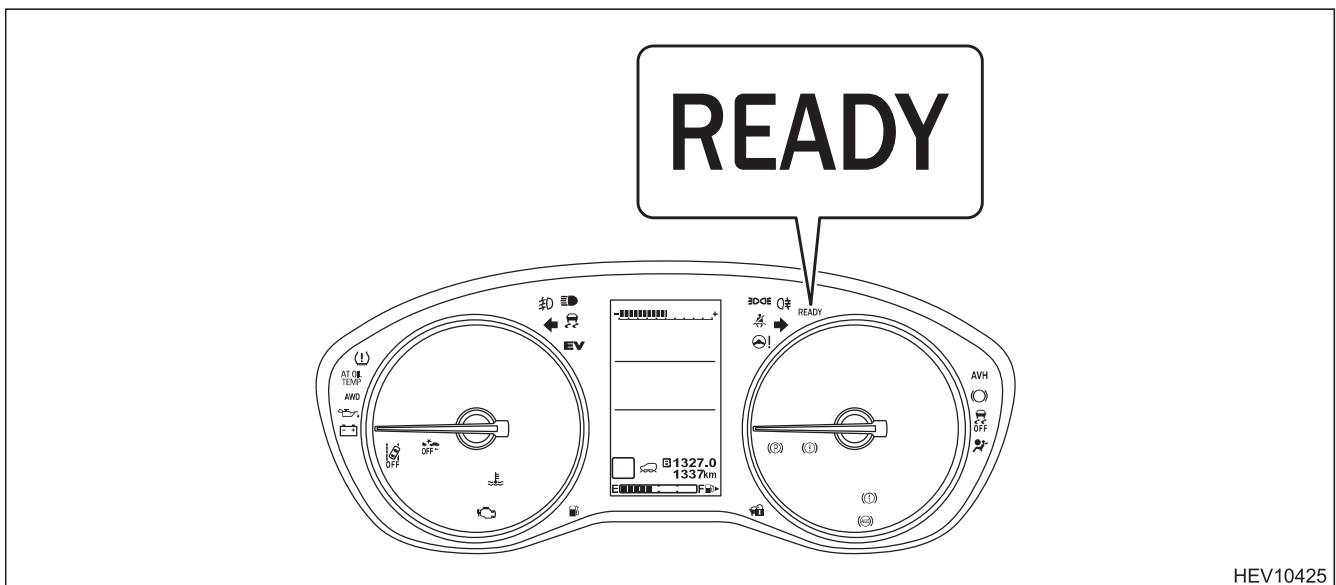

The illustration above is a typical example. For some models, the combination meter may be slightly different than that shown in the illustration.

Pedestrian Alert System

A feature on the IMPREZA e-BOXER/XV e-BOXER is the pedestrian alert system that emits a sound when the vehicle is driven using only the electric motor at speeds less than 24 km/h (15 mph). The sound is intended to notify pedestrians that the vehicle is approaching.

▼ Pedestrian Alert System

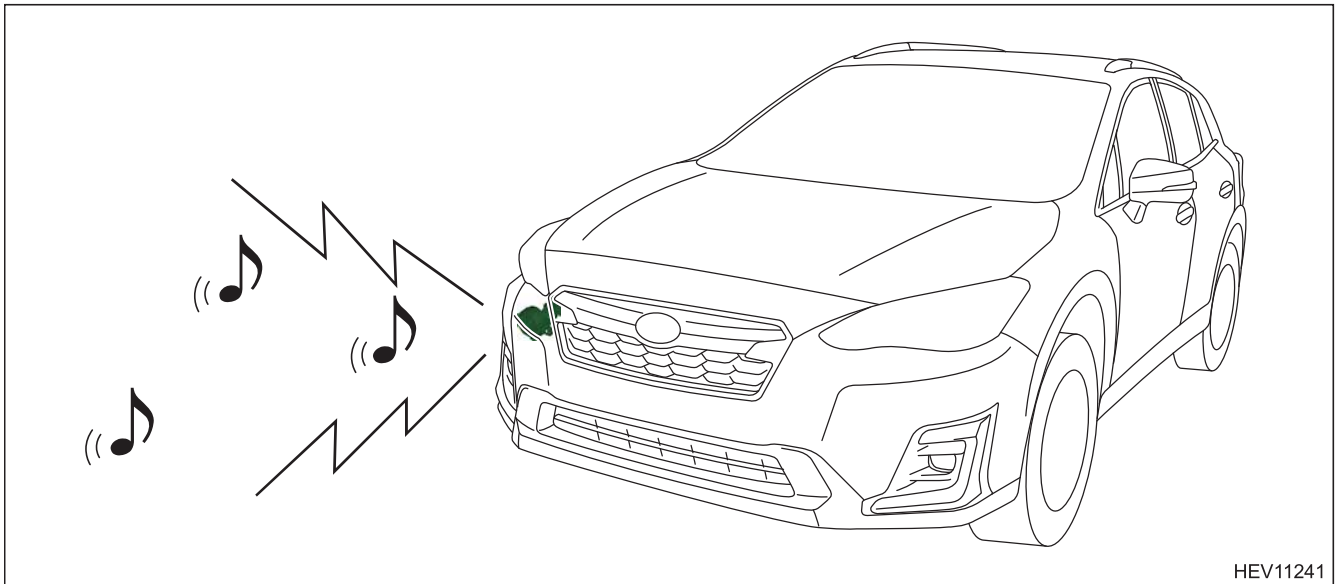

High Voltage Battery

The IMPREZA e-BOXER/XV e-BOXER features a high voltage battery that contains sealed Lithium-ion (Li-ion) battery cells.

High Voltage Battery

- The high voltage battery assembly is enclosed in a metal case and is rigidly mounted to the cross member in the cargo area behind the rear seat. The metal case is isolated from high voltage and concealed by a cargo area panel in the cabin area.
- The high voltage battery assembly consists of 3.7 Volt Li-ion battery cells connected in series circuit to produce approximately 118.4 Volts. Each Li-ion battery cell is non-spillable and contained in a sealed metal case.
- The electrolyte used in the Li-ion battery cells is a flammable organic electrolyte. The electrolyte is absorbed into the battery cell separator and will not normally leak, even in a collision.

High Voltage Battery	
High voltage battery voltage	118.4 V
Number of Li-ion battery cells in the battery	32 (16 cells×2 modules)
Li-ion battery cell voltage	3.7 V
Li-ion battery cell dimensions	12.5×120×65 mm (0.49×4.7×2.6 in)
Li-ion battery cell weight	0.181 kg (0.4 lbs)
High voltage battery dimensions	520×242×742 mm (20.5×9.5×29.2 in)
High voltage battery weight	32 kg (70.6 lbs)

Note: Values in inches have been rounded.

High Voltage Battery (Continued)

▼ High Voltage Battery

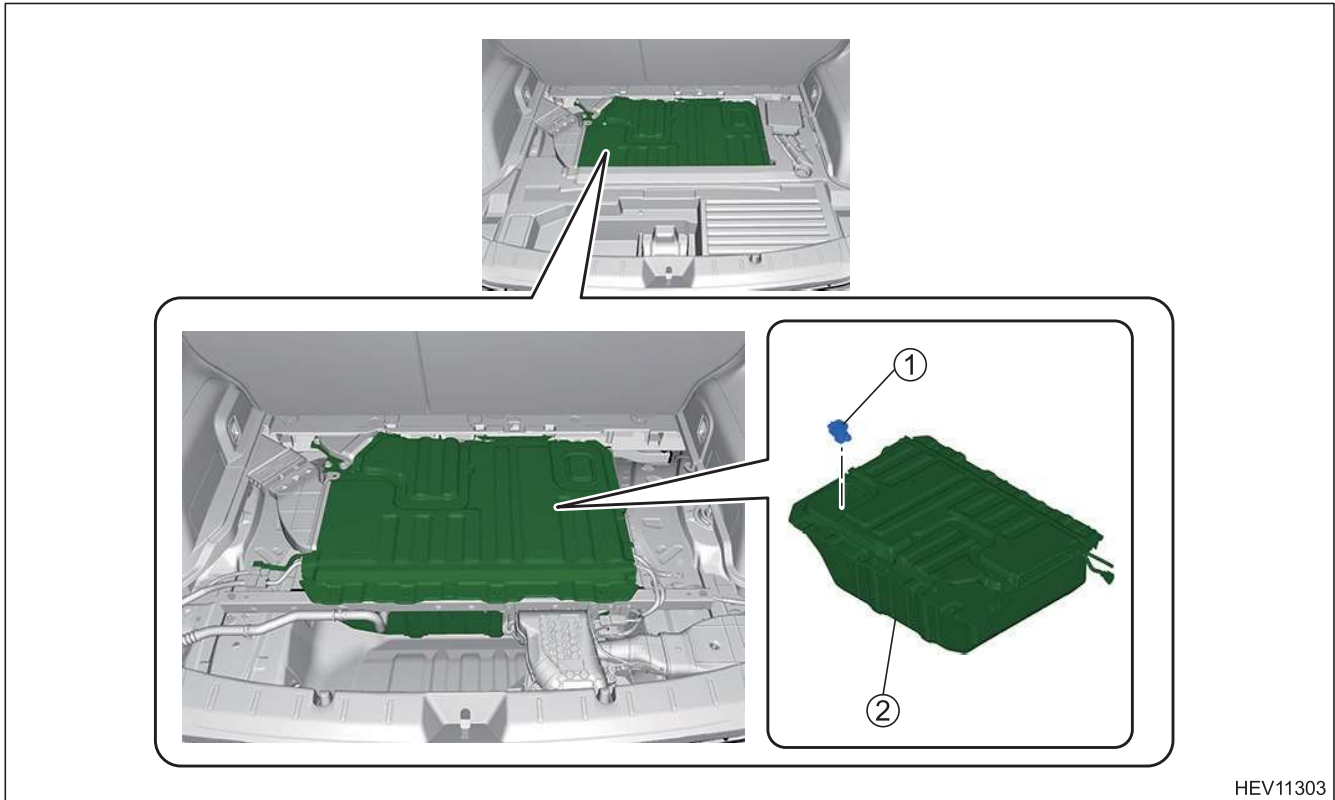

HEV11303

① Service Disconnect Plug

② High Voltage Battery

Components Powered by the High Voltage Battery

- Drive Motor
- Power Cables
- Electric Oil Pump
- Drive Motor Inverter
- Electric Oil Pump Inverter
- DC/DC Converter

Low Voltage Batteries

The IMPREZA e-BOXER/XV e-BOXER contains two sealed lead-acid 12 Volt batteries.

12 Volt Auxiliary Battery

- The 12 Volt auxiliary battery powers the vehicle's electrical system similar to a conventional vehicle. As with conventional vehicles, the negative terminal of the 12 Volt auxiliary battery is grounded to the metal chassis of the vehicle.
- The 12 Volt auxiliary battery is located in the driver side of the engine compartment. (Left-hand drive models)
- The 12 Volt auxiliary battery is located in the passenger side of the engine compartment. (Right-hand drive models)

▼ 12 Volt Auxiliary Battery

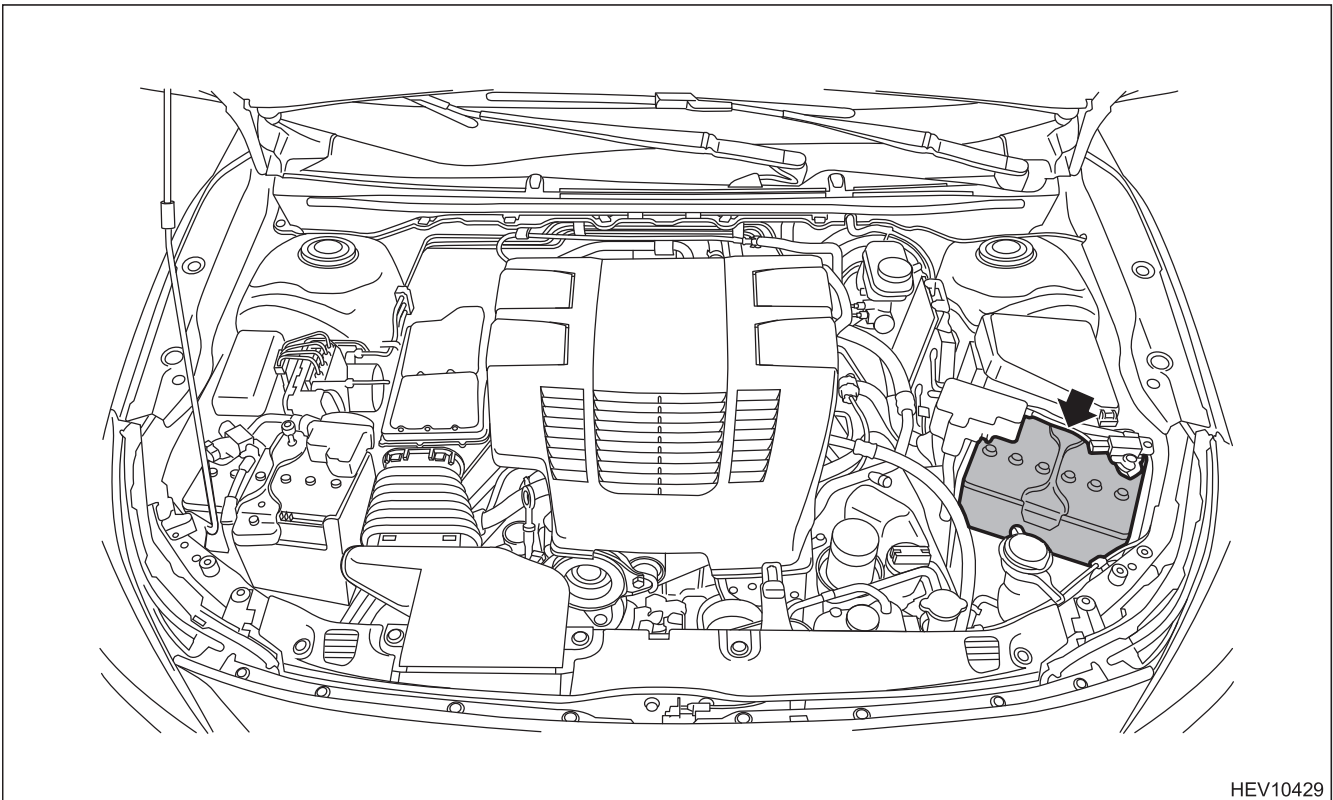

12 Volt Engine Restart Battery

- The 12 Volt engine restart battery powers the integrated starter generator. The integrated starter generator combines with the function of the alternator and the starter. It will restart the engine, during auto start stop mode or EV driving mode.
- The 12 Volt engine restart battery is located in the passenger side of the engine compartment. (Left-hand drive models)
- The 12 Volt engine restart battery is located in the driver side of the engine compartment. (Right-hand drive models)

▼ 12 Volt Engine Restart Battery

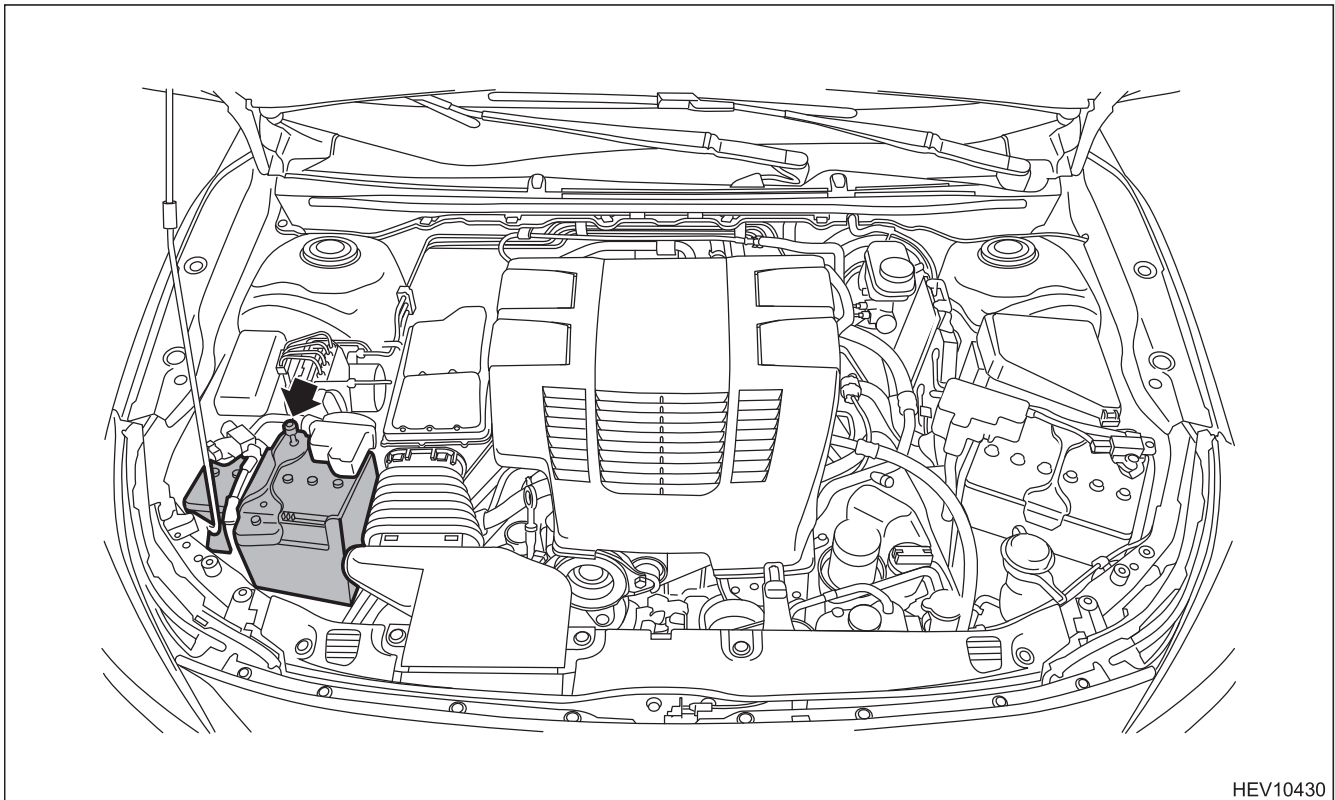

HEV10430

High Voltage Safety

The high voltage safety system is designed to help keep occupants in the vehicle and emergency responders safe from high voltage electricity:

High Voltage Safety System

▼ Vehicle Shut Off (HYBRID system READY indicator light-OFF)

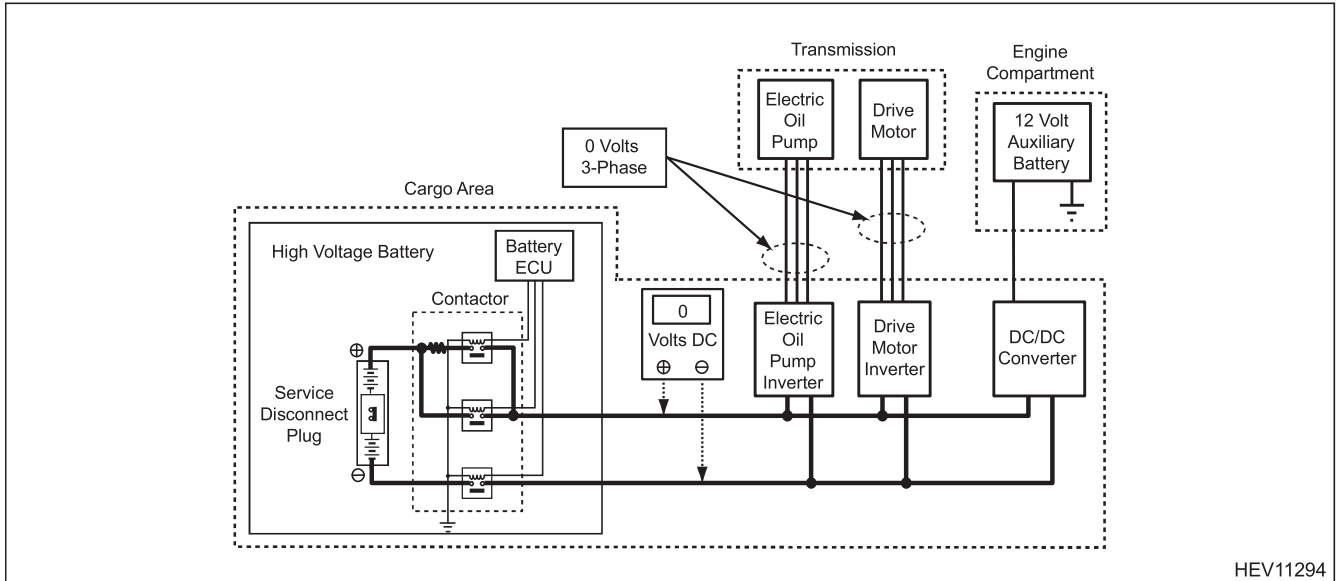

▼ Vehicle On and Operational (HYBRID system READY indicator light-ON)

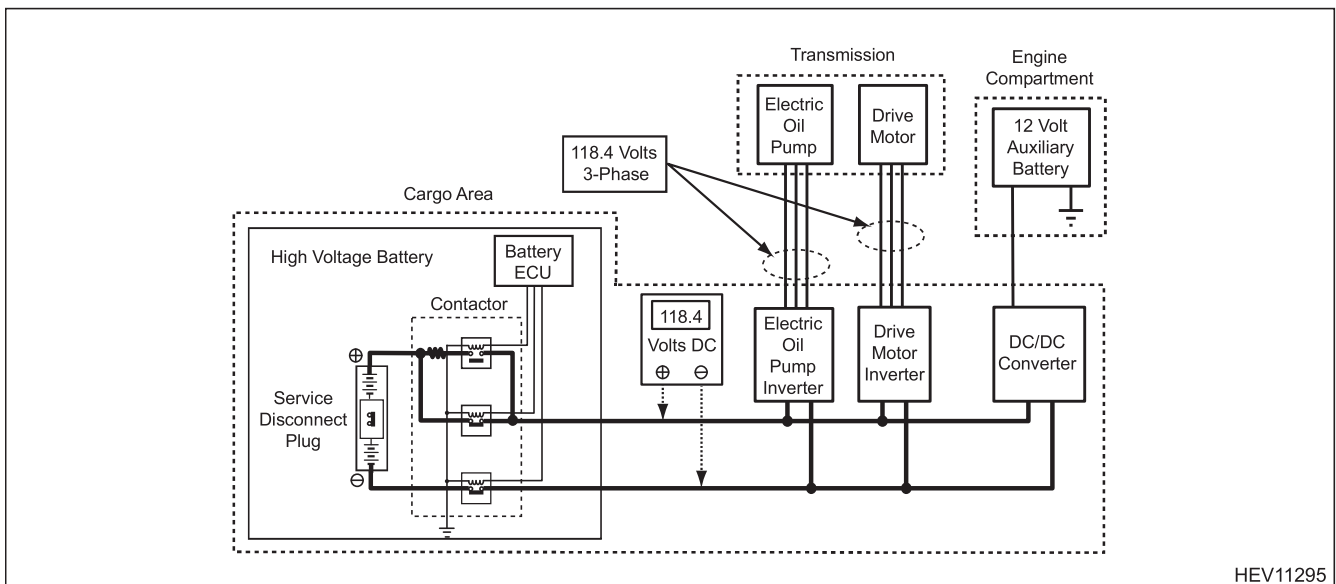

High Voltage Safety (Continued)

There are several Safety Systems incorporated into the SUBARU IMPREZA e-BOXER/XV e-BOXER vehicle designed to prevent injury from contact with high voltage.

1. The cases and covers which are placed on the high voltage system equipment, battery and wiring are incorporated to help prevent inadvertent contact with those components by humans.
2. The high voltage system is completely isolated from the vehicle body. However, if a situation occurs where the insulation or integrity is damaged, as in a collision, there are provisions to automatically disconnect the components from the high voltage battery.
3. Disconnecting high voltage from the high voltage battery to the system.

Note:

In all cases of disconnection, the system remains powered for up to 10 minutes.

There are two methods of disconnecting the high voltage from the battery to the system:

- **MANUAL OPERATION:**
By removing the service disconnect plug located on the high voltage battery case. Use of insulated rubber gloves is required for this operation even if the high voltage battery has been isolated.
- **AUTOMATIC OPERATION:**
 - Turning off the key type ignition switch or push button ignition switch.
 - Impact sensors will automatically isolate the high voltage battery when a collision is detected.

Note:

When the impact sensors are activated, the high voltage system remains disconnected until the system is reset by a SUBARU technician using the SUBARU Select Monitor. The vehicle, unless damaged severely, may be driven in a limited manner using the gasoline engine only during this time.

4. The high voltage components are either labeled or orange colored to help identify them. The power cables and connectors are identified by their orange color. Additionally, the battery and other components are labeled with High Voltage warnings and handling precautions. Always stay clear of orange cables and connectors, and other high voltage components. Always adhere to the warnings on these components. The use of insulated rubber gloves is required when working on or near these components.

WARNING:

The high voltage system may remain powered for up to 10 minutes after the vehicle is shut off or disabled. To prevent serious injury or death from severe burns or electric shock, avoid touching, cutting, or breaching any orange colored power cable or high voltage component.

SRS Airbags & Seatbelt Pretensioners

Standard Equipment

▼ SRS Airbags & Seatbelt Pretensioners

- Left-hand drive models

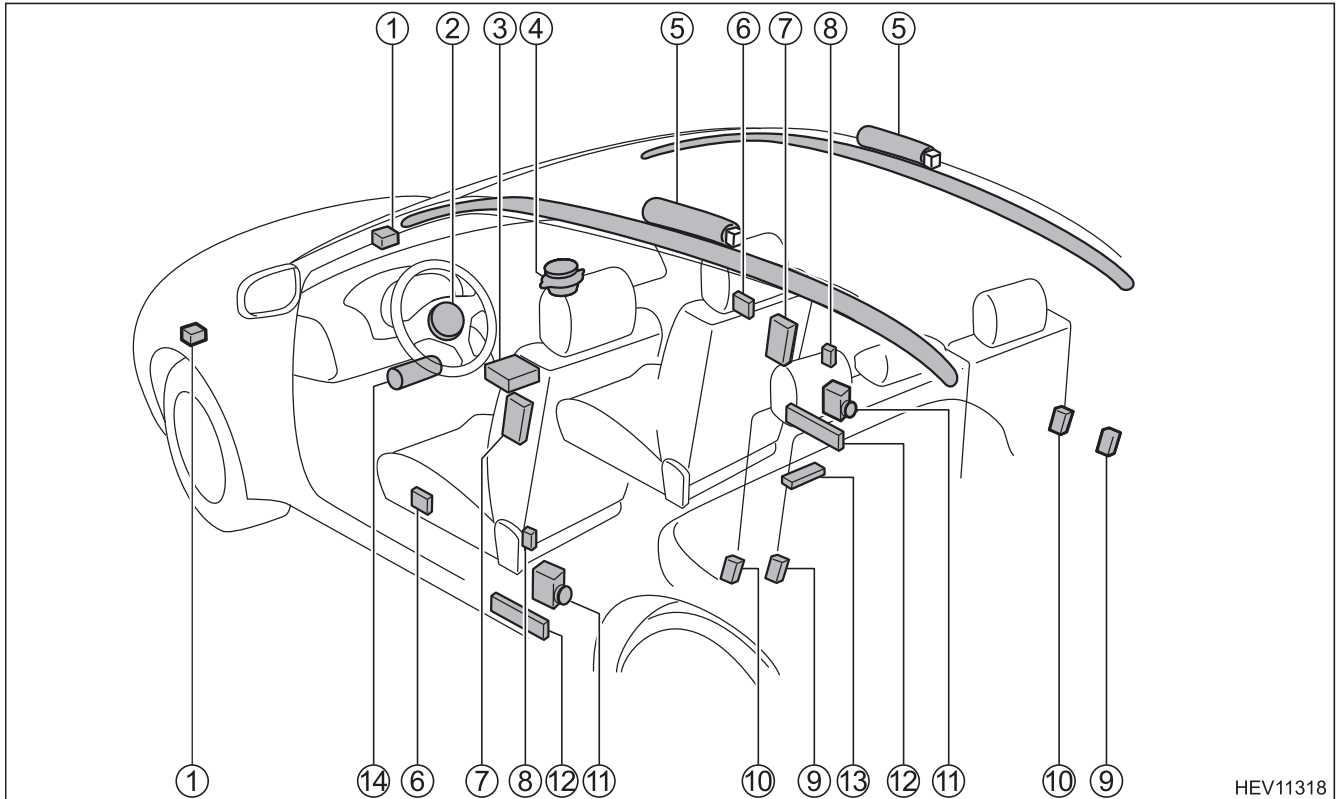

HEV11318

- Front sub sensors (2) are mounted in the engine compartment (1) as illustrated.
- Frontal airbag module (driver's side) (2) is mounted in the center position of the steering wheel.
- The airbag control module (3), which contains an impact sensor, is mounted on the floor pan underneath the instrument panel.
- Frontal airbag module (passenger's side) (4) is integrated into the dashboard and deploys through the top of the dashboard.
- Curtain airbag modules (5) are mounted along the outer edge inside the roof rails.
- Front door impact sensors (2) are mounted inside the base of the front doors. (6)
- Side airbag modules (7) are mounted in the front seatbacks.
- Side airbag sensors (2) are mounted near the base of the center pillars. (8)
- Rear seatbelt pretensioners are mounted near the base of the rear pillars. (9)
- Curtain airbag sensors (2) are mounted near the rear wheel house. (10)
- Seatbelt pretensioners are mounted near the base of the center pillars. (11)
- Lap belt pretensioners are mounted near the base of the center pillars. (12)
- Satellite safing sensor (13) is mounted under the rear center seat.
- Knee airbag module (14) is mounted on the bottom of the steering column.

SRS Airbags & Seatbelt Pretensioners (Continued)

- Right-hand drive models

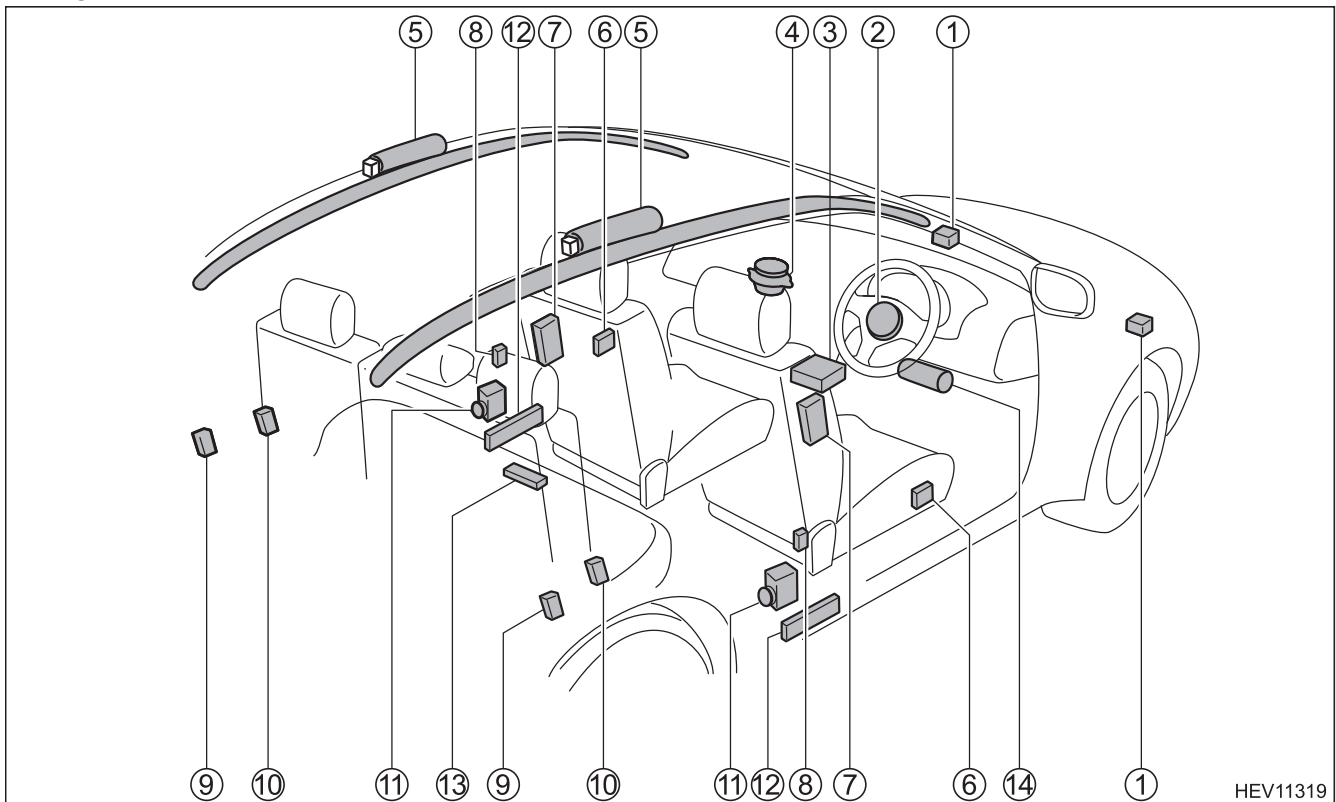

HEV11319

- Front sub sensors (2) are mounted in the engine compartment (1) as illustrated.
- Frontal airbag module (driver's side) (2) is mounted in the center position of the steering wheel.
- The airbag control module (3), which contains an impact sensor, is mounted on the floor pan underneath the instrument panel.
- Frontal airbag module (passenger's side) (4) is integrated into the dashboard and deploys through the top of the dashboard.
- Curtain airbag modules (5) are mounted along the outer edge inside the roof rails.
- Front door impact sensors (2) are mounted inside the base of the front doors. (6)
- Side airbag modules (7) are mounted in the front seatbacks.
- Side airbag sensors (2) are mounted near the base of the center pillars. (8)
- Rear seatbelt pretensioners are mounted near the base of the rear pillars. (9)
- Curtain airbag sensors (2) are mounted near the rear wheel house. (10)
- Seatbelt pretensioners are mounted near the base of the center pillars. (11)
- Lap belt pretensioners are mounted near the base of the center pillars. (12)
- Satellite safing sensor (13) is mounted under the rear center seat.
- Knee airbag module (14) is mounted on the bottom of the steering column.

WARNING:

The SRS may remain powered for up to 60 seconds after the vehicle is shut off or disabled. To prevent serious injury or death from unintentional SRS deployment, avoid breaching the SRS components.

SRS Airbags & Seatbelt Pretensioners (Continued)

Note:

The front seatback mounted side airbags and the curtain airbags may deploy independently of each other.

The knee airbag (driver's side only) and passenger frontal airbag are designed to deploy simultaneously with the frontal airbag.

Electronic side impact sensors are installed in each front door to aid in side collision detection accuracy.

▼ Frontal, Knee, Side, Curtain Airbags

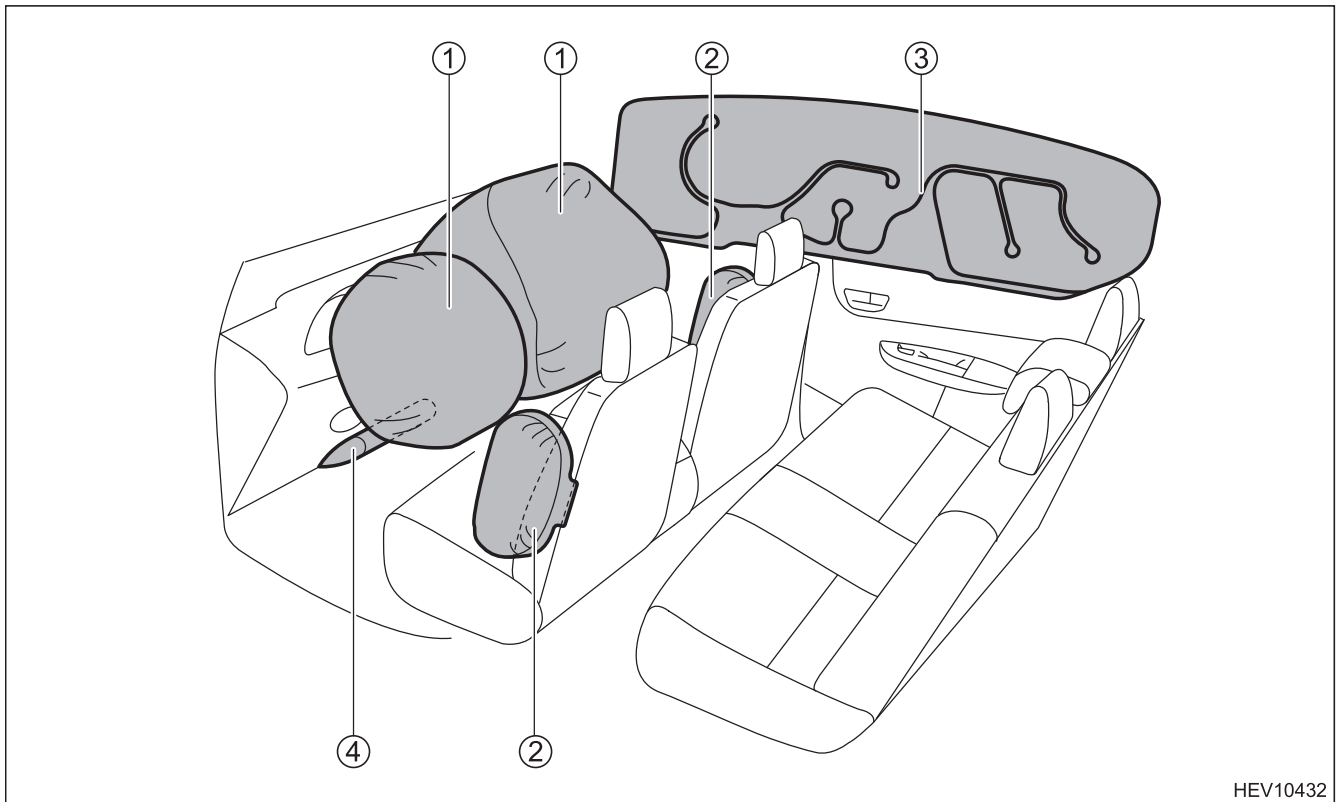

HEV10432

- ① Frontal Airbag
- ② Side Airbag

- ③ Curtain Airbag
- ④ Knee Airbag

SRS Airbags & Seatbelt Pretensioners (Continued)

▼ Airbag System Wiring

- Left-hand drive models

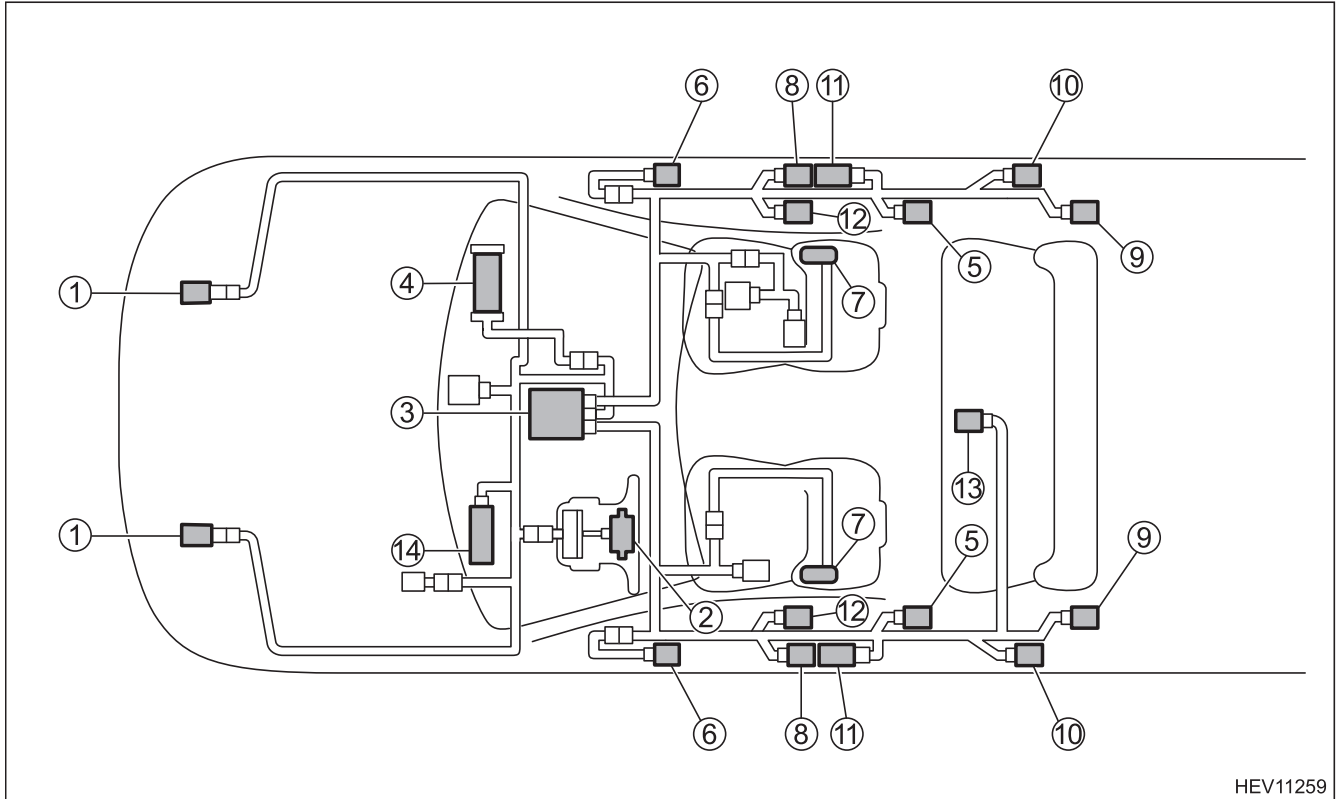

- ① Front Sub Sensors
- ② Frontal Airbag Module (driver's side)
- ③ Airbag Control Module
- ④ Frontal Airbag Module (passenger's side)
- ⑤ Curtain Airbag Modules
- ⑥ Front Door Impact Sensors
- ⑦ Side Airbag Modules

- ⑧ Side Airbag Sensors
- ⑨ Rear Seatbelt Pretensioners
- ⑩ Curtain Airbag Sensors
- ⑪ Seatbelt Pretensioners
- ⑫ Lap Belt Pretensioners
- ⑬ Satellite Safing Sensor
- ⑭ Knee Airbag Module

SRS Airbags & Seatbelt Pretensioners (Continued)

- Right-hand drive models

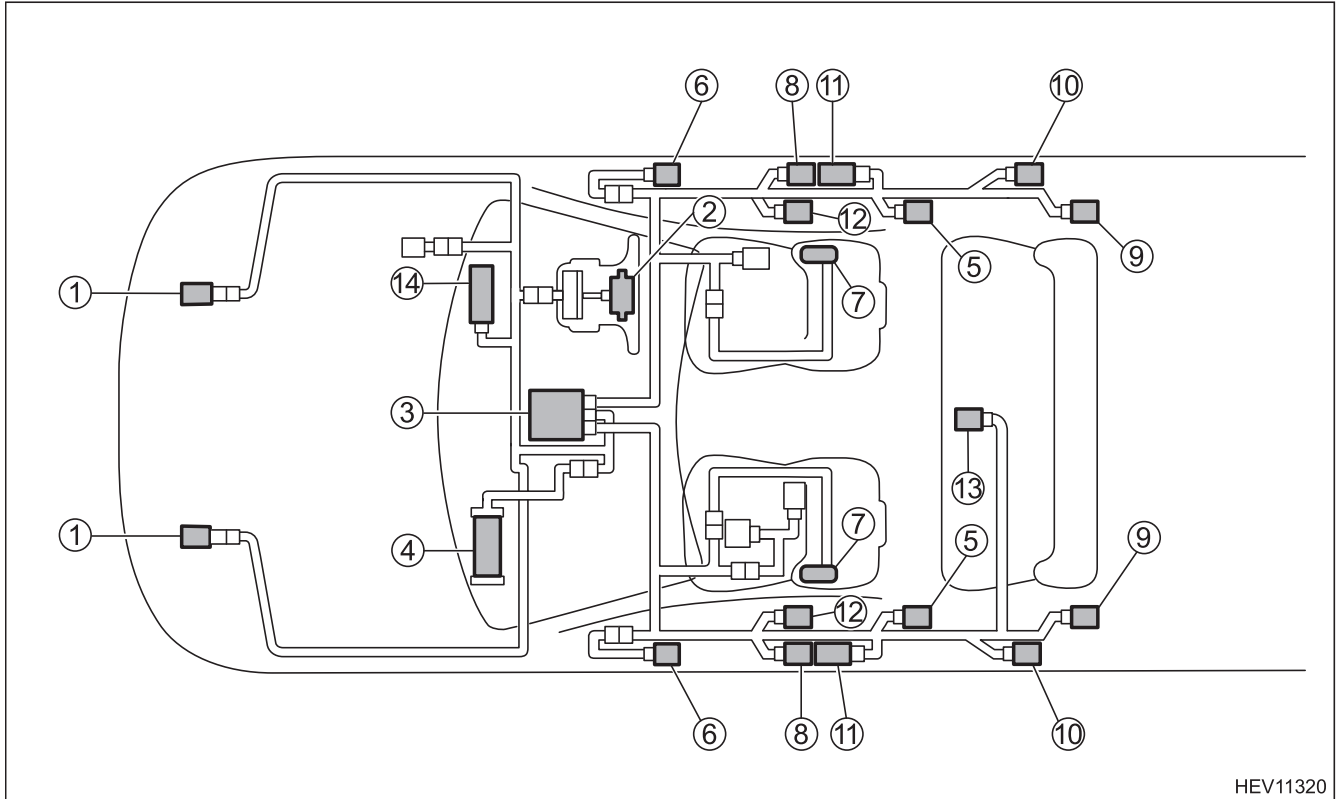

HEV11320

- | | |
|--|-------------------------------|
| ① Front Sub Sensors | ⑧ Side Airbag Sensors |
| ② Frontal Airbag Module (driver's side) | ⑨ Rear Seatbelt Pretensioners |
| ③ Airbag Control Module | ⑩ Curtain Airbag Sensors |
| ④ Frontal Airbag Module (passenger's side) | ⑪ Seatbelt Pretensioners |
| ⑤ Curtain Airbag Modules | ⑫ Lap Belt Pretensioners |
| ⑥ Front Door Impact Sensors | ⑬ Satellite Safing Sensor |
| ⑦ Side Airbag Modules | ⑭ Knee Airbag Module |

Emergency Response

On arrival, emergency responders should follow their standard operating procedures for vehicle incidents. Emergencies involving the IMPREZA e-BOXER/XV e-BOXER may be handled like other automobiles except as noted in these guidelines for Extrication, Fire, Overhaul, Recovery, Spills, First Aid, and Submersion.

WARNING:

- *Never assume the IMPREZA e-BOXER/XV e-BOXER is shut off simply because it is silent.*
- *Always observe the combination meter for the HYBRID system READY indicator light status to verify whether the vehicle is on or shut off. The vehicle is shut off when the HYBRID system READY indicator light is off.*
- *Failure to shut off and disable the vehicle before emergency response procedures are performed may result in serious injury or death from the unintentional deployment of the SRS or severe burns and electric shock from the high voltage electrical system.*

Extrication

■ Immobilize Vehicle

Chock wheels and set the parking brake.
Shift the select lever to the Park position.

▼ Chock Wheels

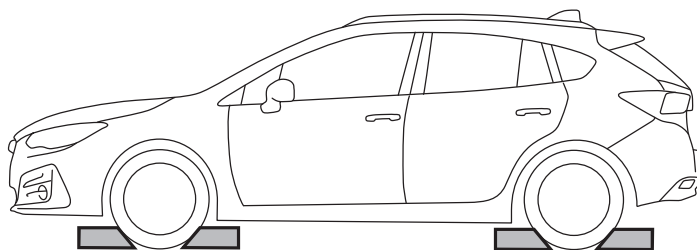

HEV10433

Emergency Response (Continued)

▼ Set Parking Brake

- Left-hand drive models

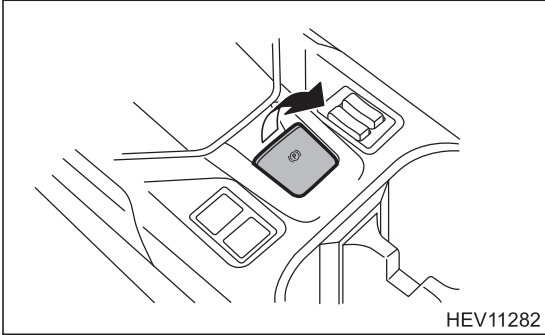

- Right-hand drive models

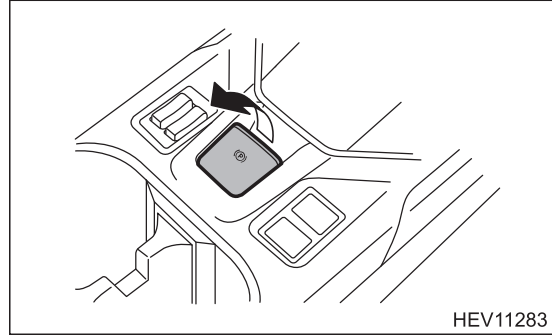

▼ Select Lever in Park

- Left-hand drive models

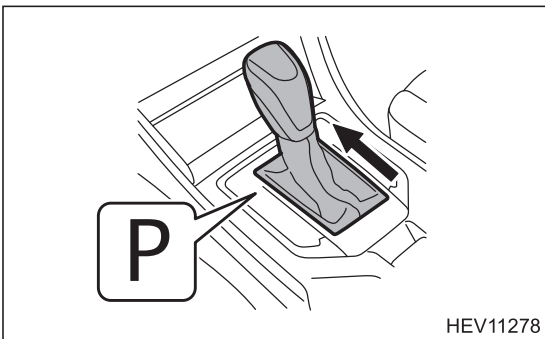

- Right-hand drive models

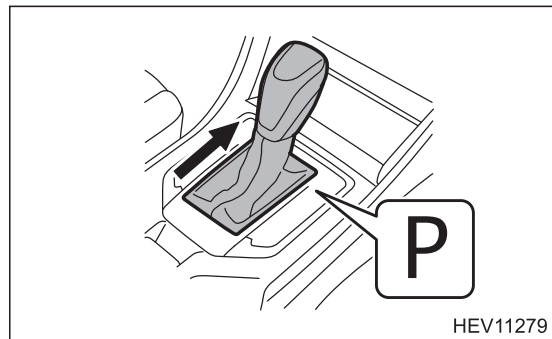

Emergency Response (Continued)

■ Disable Vehicle

Performing any one of the following three procedures will shut the vehicle off and disable the high voltage battery, SRS, and gasoline fuel pump.

Procedure #1

Mechanical Ignition Key System (Standard Equipment):

Note:

Before shutting off the vehicle and disconnecting the 12 Volt auxiliary battery, if necessary, lower the windows, unlock the doors and open the rear gate as required. Once the 12 Volt auxiliary battery is disconnected, power controls will not operate.

1. Confirm the status of the HYBRID system READY indicator light in the combination meter.
2. If the HYBRID system READY indicator light is illuminated, the vehicle is on and operational. Shut off the vehicle by turning the ignition key off, removing the ignition key and placing it on the dash.

Note:

If the ignition switch will not move from the "LOCK" (off) position to the "ACC" position, turn the steering wheel slightly to the left and right as you turn the ignition switch.

▼ HYBRID system READY indicator light

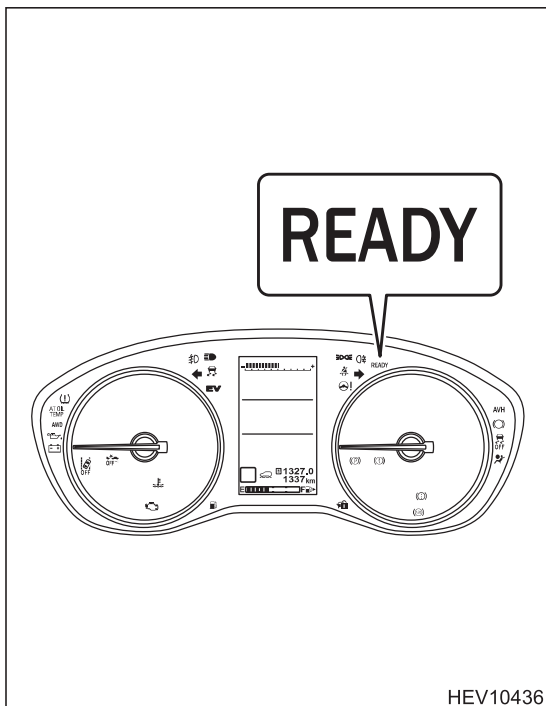

▼ Turn Ignition Key Off

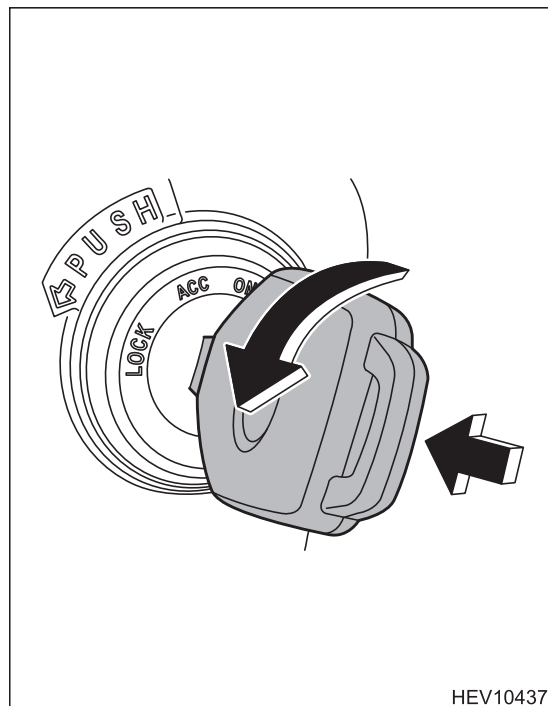

The illustration above is a typical example. For some models, the combination meter may be slightly different than that shown in the illustration.

Emergency Response (Continued)

3. Open the hood.
4. Disconnect the battery ground terminal of both the 12 Volt auxiliary battery and the 12 Volt engine restart battery in the engine compartment.

▼ Hood Release Knob

- Left-hand drive models

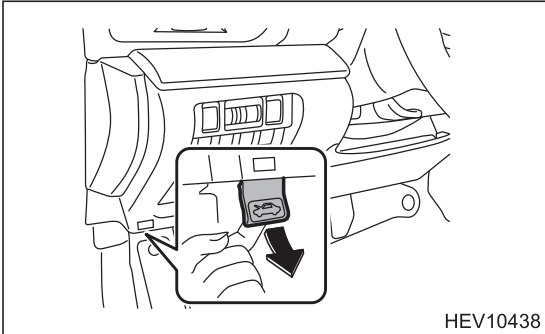

- Right-hand drive models

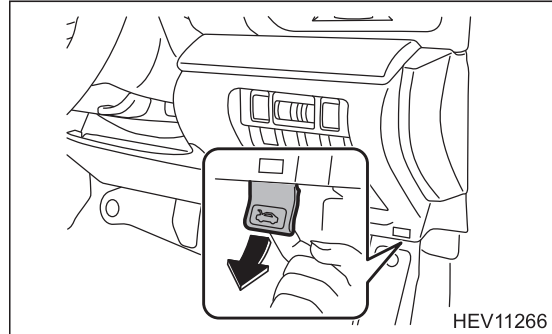

▼ Hood Latch Release

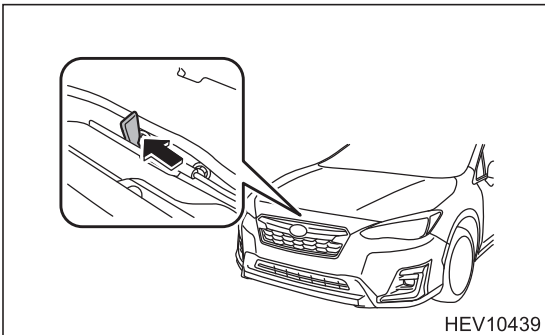

▼ 12 Volt Auxiliary Battery

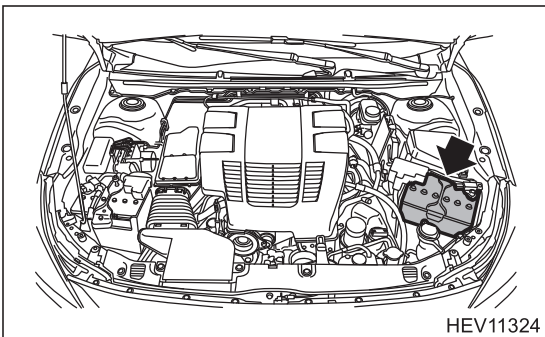

▼ 12 Volt Engine Restart Battery

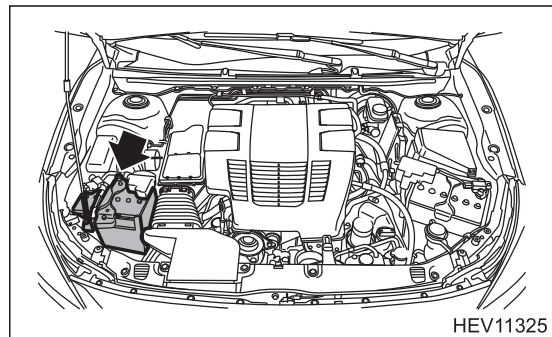

Keyless Access with Push-button Start System (Optional Equipment):

Note:

Before shutting off the vehicle and disconnecting the 12 Volt auxiliary battery, if necessary, lower the windows, unlock the doors and open the rear gate as required. Once the 12 Volt auxiliary battery is disconnected, power controls will not operate.

1. Confirm the status of the HYBRID system READY indicator light in the combination meter.
2. If the HYBRID system READY indicator light is illuminated, the vehicle is on and operational. Shut off the vehicle by pushing the push-button ignition switch once.
3. The vehicle is already shut off if the combination meter lights and the HYBRID system READY indicator light are not illuminated. Do not push the push-button ignition switch because the vehicle may start.
4. If the access key fob is easily accessible, keep it at least 5 meters (16 feet) away from the vehicle.

▼ HYBRID system READY indicator light

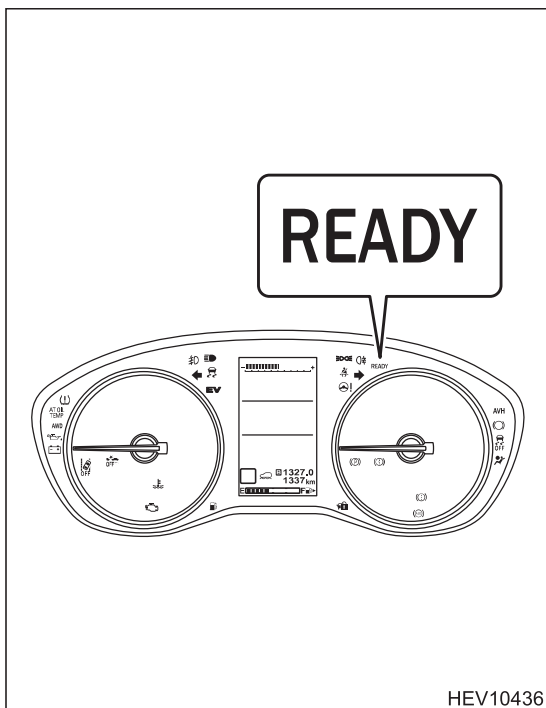

The illustration above is a typical example. For some models, the combination meter may be slightly different than that shown in the illustration.

Emergency Response (Continued)

▼ Shut Off Vehicle (HYBRID system READY indicator light-OFF)

- Left-hand drive models

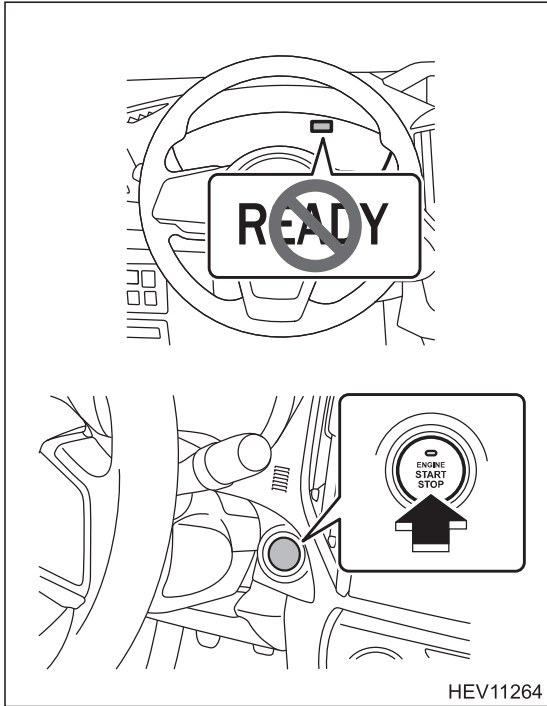

- Right-hand drive models

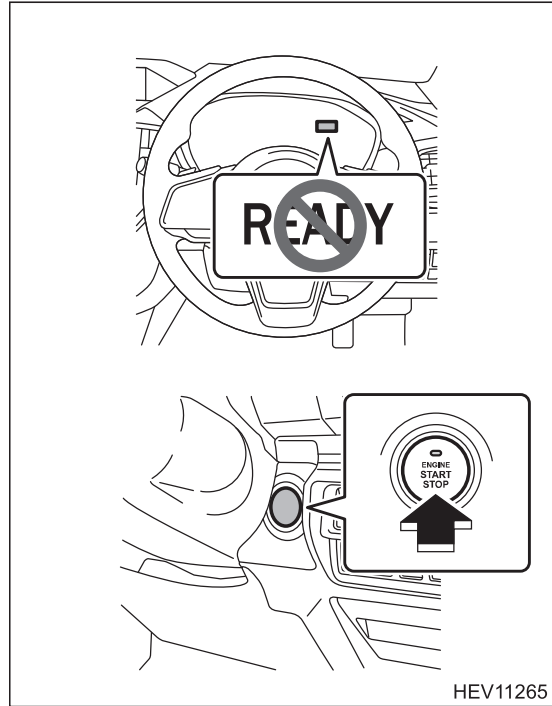

Emergency Response (Continued)

5. Open the hood.
6. Disconnect the battery ground terminal of both the 12 Volt auxiliary battery and the 12 Volt engine restart battery in the engine compartment.

▼ Hood Release Knob

- Left-hand drive models

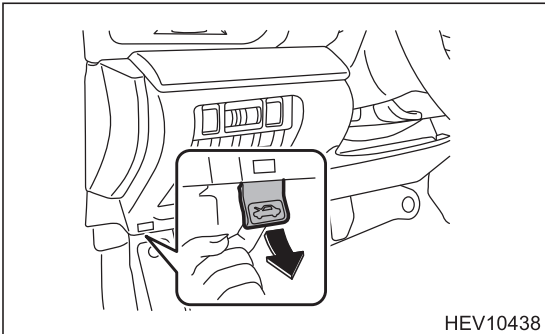

- Right-hand drive models

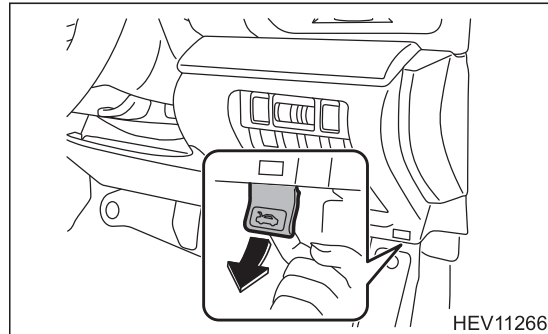

▼ Hood Latch Release

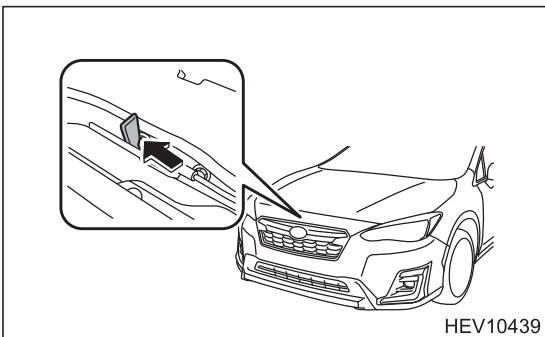

▼ 12 Volt Auxiliary Battery

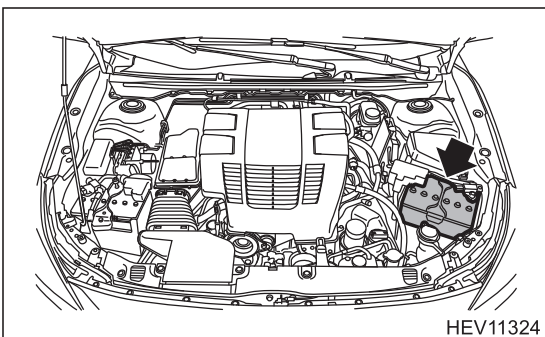

▼ 12 Volt Engine Restart Battery

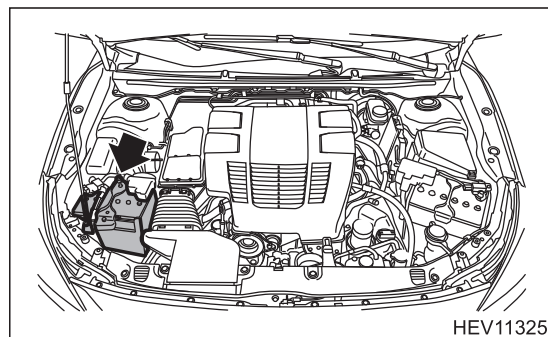

Emergency Response (Continued)

Procedure #2 (Alternate if push-button ignition switch or ignition key is inaccessible)

Note:

Before shutting off the vehicle and disconnecting the 12 Volt auxiliary battery, if necessary, lower the windows, unlock the doors and open the rear gate as required. Once the 12 Volt auxiliary battery is disconnected, power controls will not operate.

1. Open the hood.

▼ Hood Release Knob

- Left-hand drive models

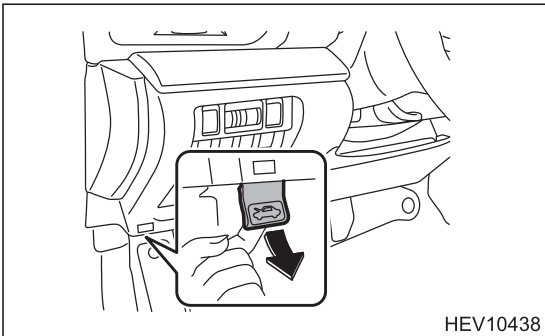

- Right-hand drive models

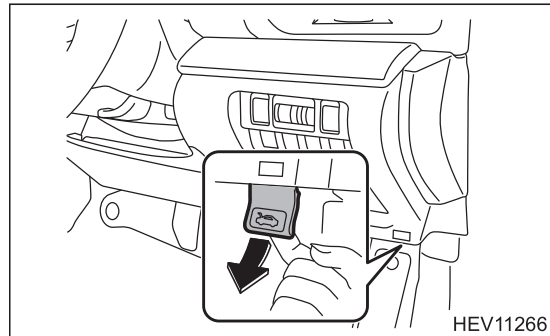

▼ Hood Latch Release

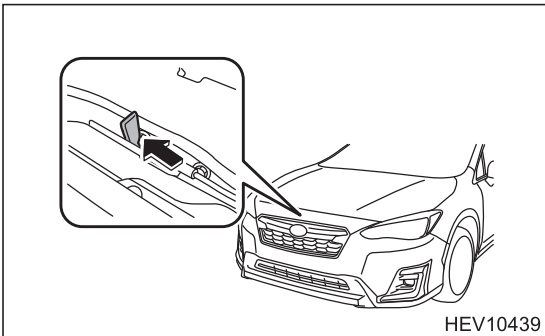

Emergency Response (Continued)

2. Remove the fuse box cover.
3. Remove the SBF No.4 fuse (30 A) in the engine compartment fuse box (refer to illustration). If the correct fuse cannot be recognized, pull all fuses in the fuse box.
4. Disconnect the battery ground terminal of both the 12 Volt auxiliary battery and the 12 Volt engine restart battery in the engine compartment.

▼ Fuse Box Cover

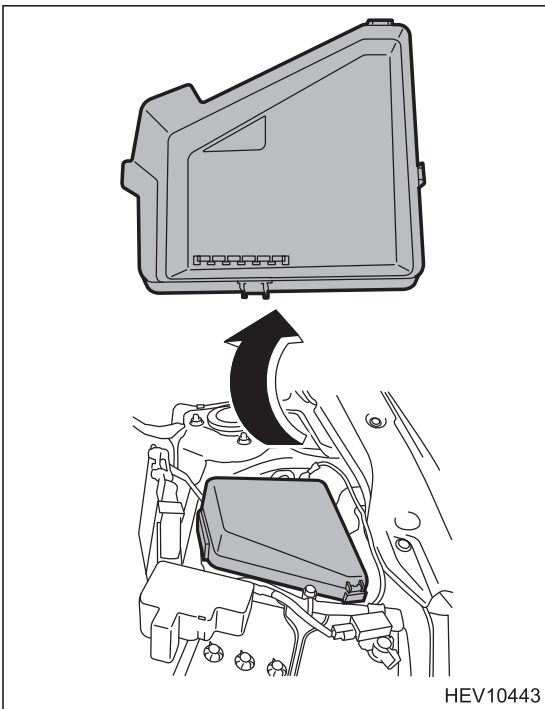

▼ SBF No.4 Fuse (30A) in Engine Compartment Fuse Box

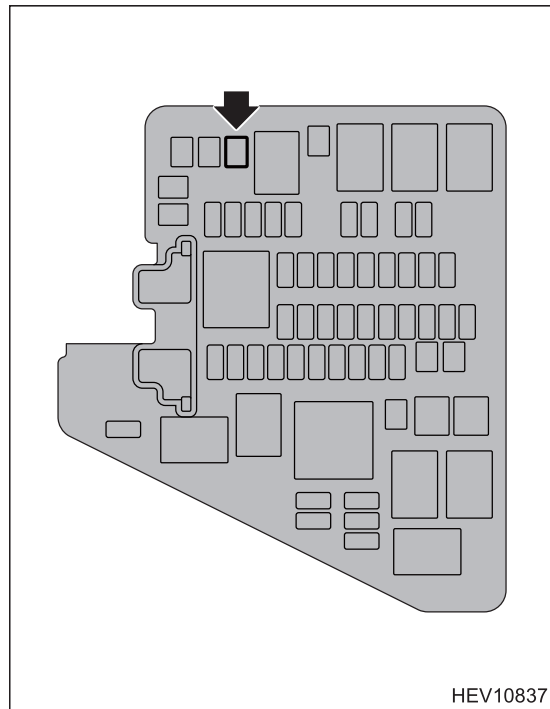

▼ 12 Volt Auxiliary Battery

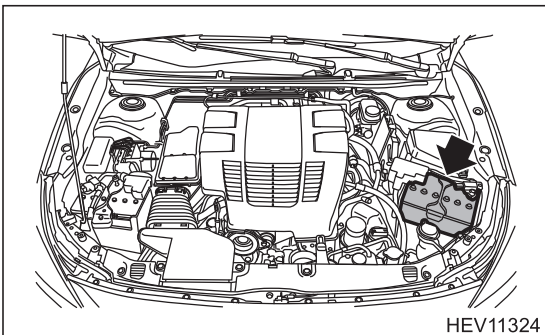

▼ 12 Volt Engine Restart Battery

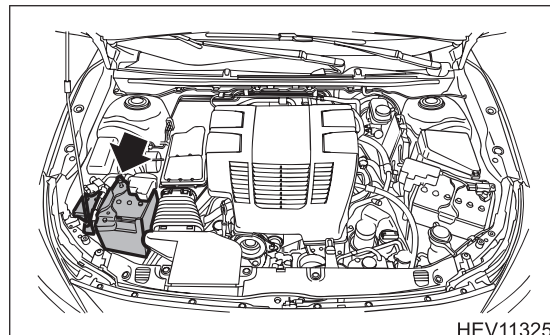

Emergency Response (Continued)

Procedure #3 (If procedures 1 and 2 cannot be implemented and insulated rubber gloves can be used)

Note:

Before shutting off the vehicle and disconnecting the 12 Volt auxiliary battery, if necessary, lower the windows, unlock the doors and open the rear gate as required. Once the 12 Volt auxiliary battery is disconnected, power controls will not operate.

1. Open the rear gate and remove the cargo area cover.
2. Unscrew the bolt and remove the service disconnect plug cover.
3. Wear insulated rubber gloves and then remove the service disconnect plug (refer to illustration).
 - ① Slide the lever toward rear of vehicle.
 - ② Raise the lever until it is vertical.
 - ③ Pull the lever upward and remove the service disconnect plug from the high voltage battery holder.

▼ Rear Gate Opener Button

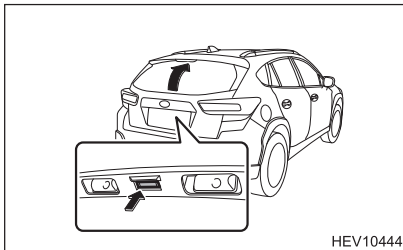

▼ Open the Cargo Area Lid

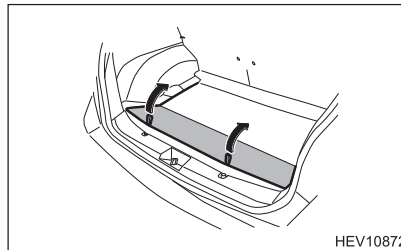

▼ Service Disconnect Plug Cover

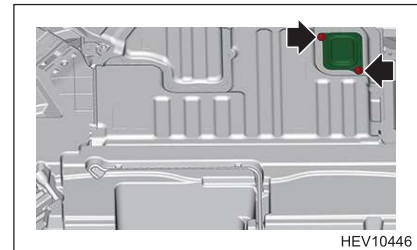

▼ Service Disconnect Plug

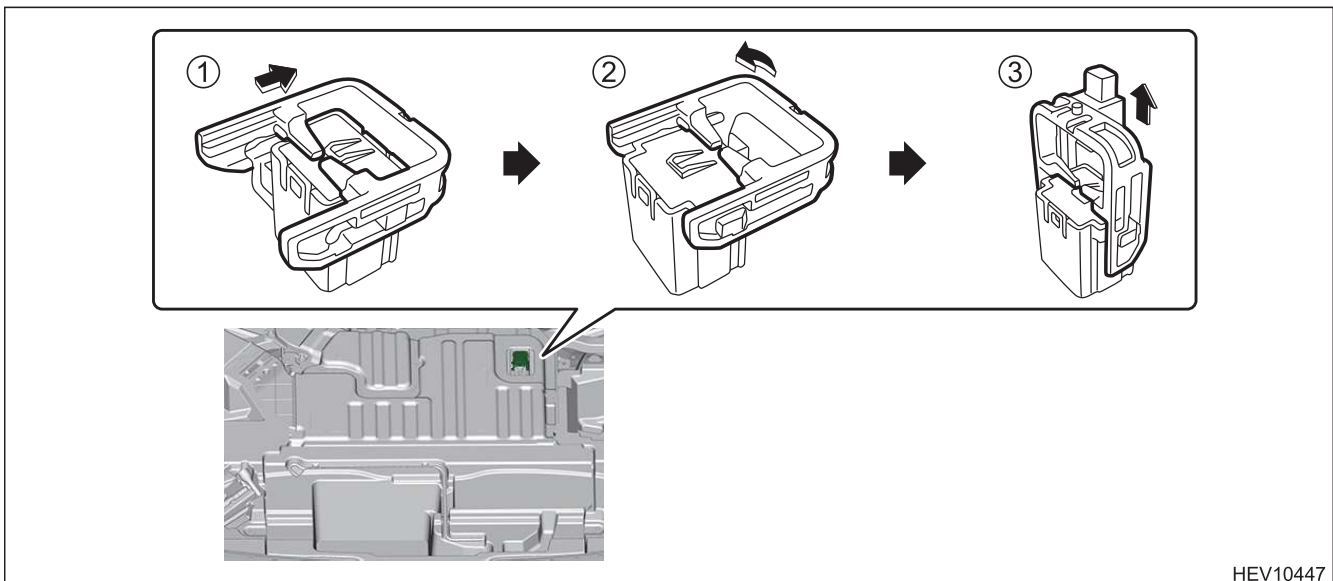

Emergency Response (Continued)

WARNING:

- You must wear insulated rubber gloves to prevent serious injury or death from severe burns or electric shock.
- Be sure to carry the service disconnect plug on your person after you remove it to prevent another person from re-connecting it by mistake.
- The high voltage system may remain powered for up to 10 minutes after the vehicle is shut off or disabled. To prevent serious injury or death from severe burns or electric shock, avoid touching, cutting, or breaching any orange colored power cable or high voltage component.
- Before touching any high voltage parts, wiring, terminals or connector after the service disconnect plug has been removed, wait more than 10 minutes for the high voltage charge in the capacitor to discharge.
- The SRS may remain powered for up to 60 seconds after the vehicle is shut off or disabled. To prevent serious injury or death from unintentional SRS deployment, avoid breaching the SRS components.
- If none of the disabling procedures can be performed, proceed with caution as there is no assurance that the high voltage electrical system, SRS, or fuel pump are disabled.

4. Open the hood.
5. Disconnect the battery ground terminal of both the 12 Volt auxiliary battery and the 12 Volt engine restart battery in the engine compartment.

▼ Hood Release Knob

- Left-hand drive models

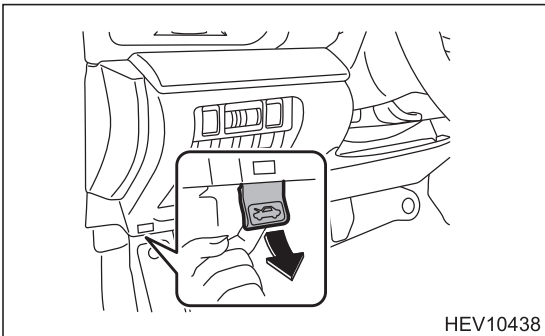

- Right-hand drive models

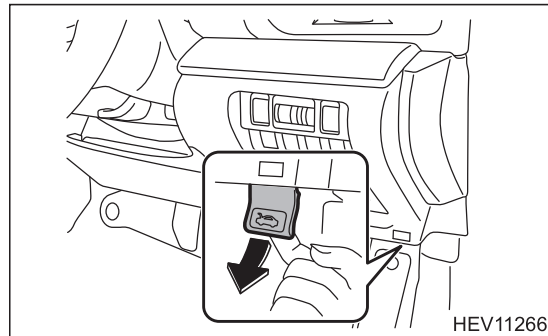

▼ Hood Latch Release

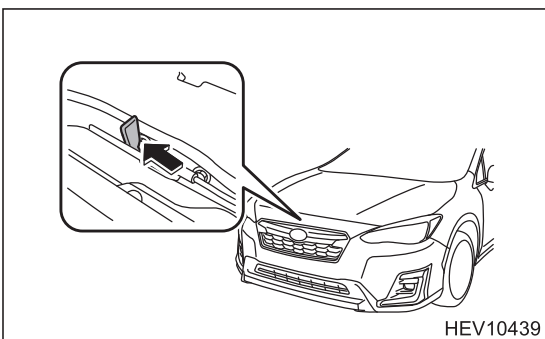

Emergency Response (Continued)

▼ 12 Volt Auxiliary Battery

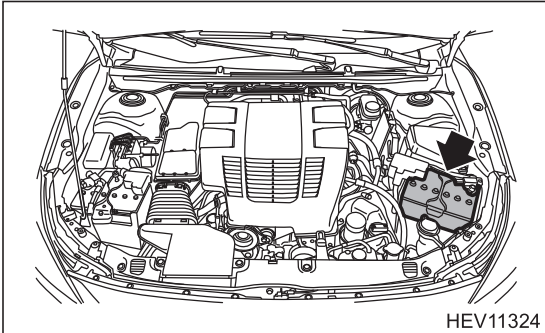

▼ 12 Volt Engine Restart Battery

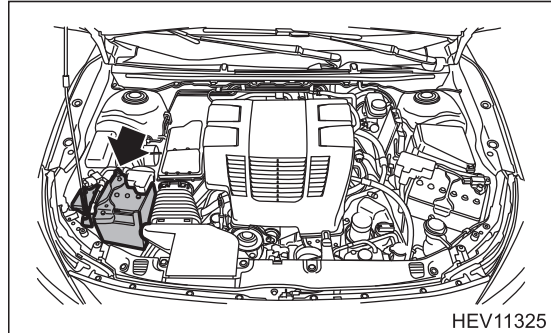

Emergency Response (Continued)

■ Stabilize Vehicle

Crib at (4) points directly under the front and side sills.

Do not place cribbing under the orange colored power cables, exhaust system, or fuel system.

Note:

The IMPREZA e-BOXER/XV e-BOXER is equipped with a tire pressure monitoring system that by design prevents pulling the valve stem with integral transmitter from the wheel. Snapping the valve stem with pliers or removing the valve cap and Valve core will release the air in the tire.

▼ Cribbing Points

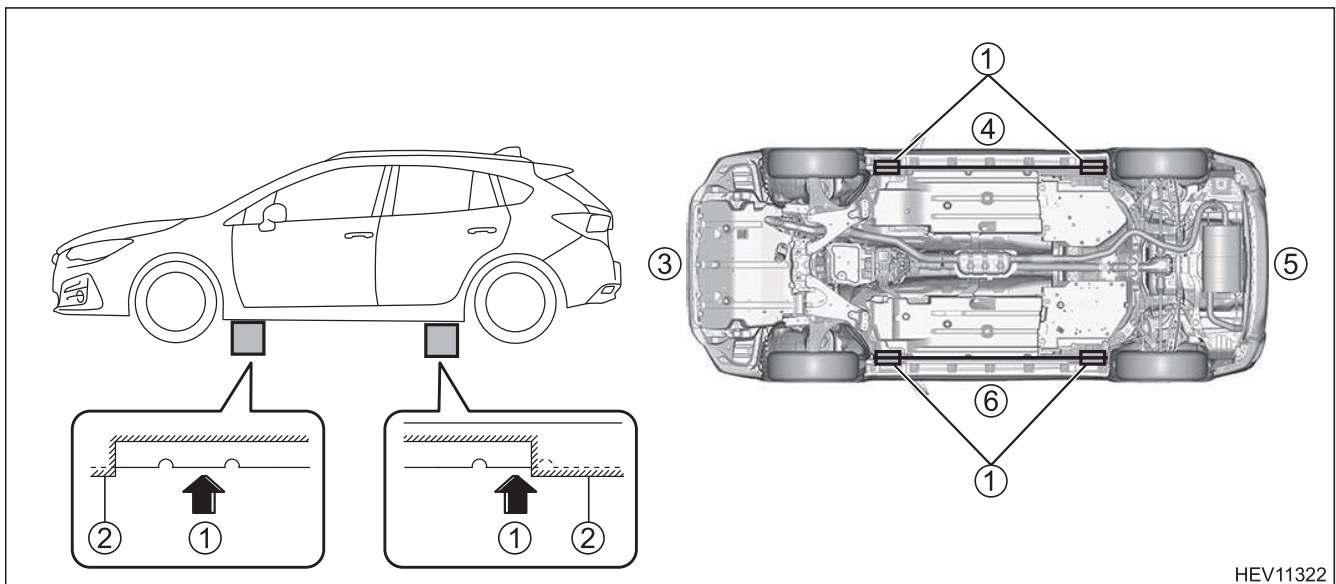

HEV11322

- ① Cribbing Points
- ② Side Sill Garnish
- ③ Fr

- ④ LH
- ⑤ Rr
- ⑥ RH

▼ Valve Stem with Integral Transmitter



HEV10449

▼ Valve Stem with Integral Transmitter Installed on Wheel

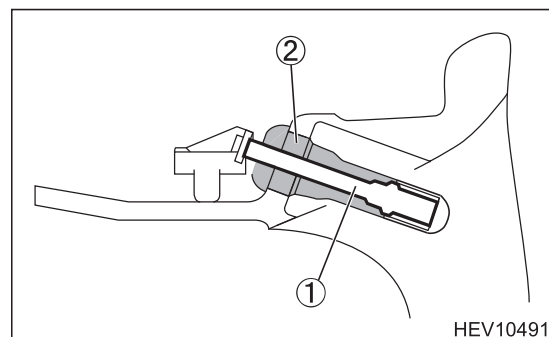

HEV10491

- ① Metal

- ② Rubber

Emergency Response (Continued)

■ Access Patients

Glass Removal

Use normal glass removal procedures as required.

SRS Awareness

Responders need to be cautious when working in close proximity to undeployed airbags and seatbelt pretensioners. Front airbags automatically deploy within a fraction of a second of being triggered.

Door Removal/Displacement

Doors can be removed by conventional rescue tools such as hand, electric, and hydraulic tools. In certain situations, it may be easier to pry back the vehicle body to expose and unbolt the hinges.

Note:

To prevent accidental airbag deployment when performing front door removal/displacement, ensure the vehicle is shut off and the 12 Volt auxiliary battery is disconnected.

Roof Removal

The IMPREZA e-BOXER/XV e-BOXER is equipped with curtain airbags.

When undeployed, total roof removal is not recommended.

Patient access through the roof can be performed by cutting the roof center section inboard of the roof rails as illustrated. This would avoid breaching the curtain airbags, inflators, and wiring harness.

Note:

The curtain airbags may be identified as illustrated on this page (additional component details on page 29).

▼ Side, Curtain, and Knee Airbag Identifiers

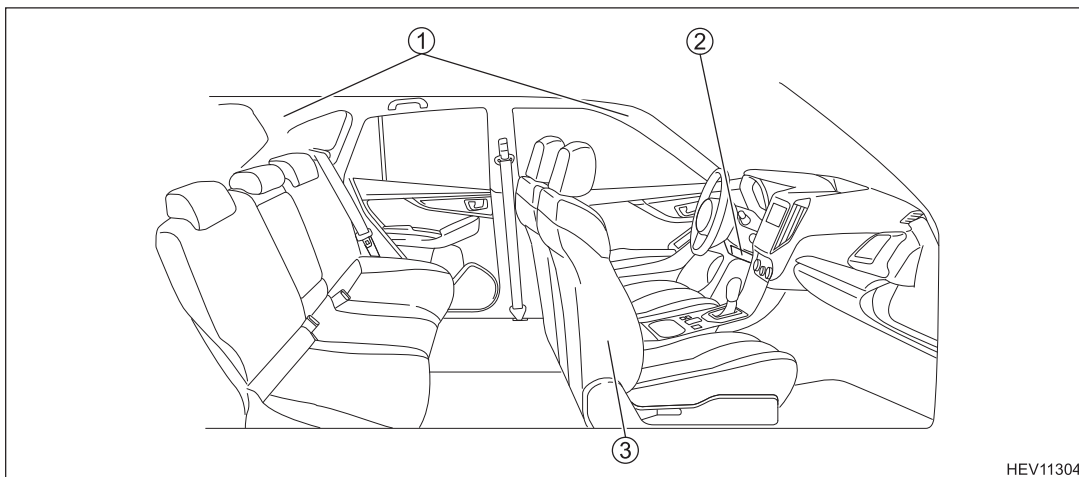

- ① SRS Curtain Airbag
- ② SRS Knee Airbag

- ③ SRS Side Airbag

Emergency Response (Continued)

Dash Displacement

The IMPREZA e-BOXER/XV e-BOXER is equipped with curtain airbags. When undeployed, total roof removal is not recommended to avoid breaching the side curtain airbags, inflators, and wiring harness.

As an alternative, dash displacement may be performed by using a “Modified Dash Roll Technique”.

Rescue Lift Airbags

Responders should not place cribbing or rescue lift airbags under the orange colored power cables, exhaust system, or fuel system.

▼ Roof Removal Area

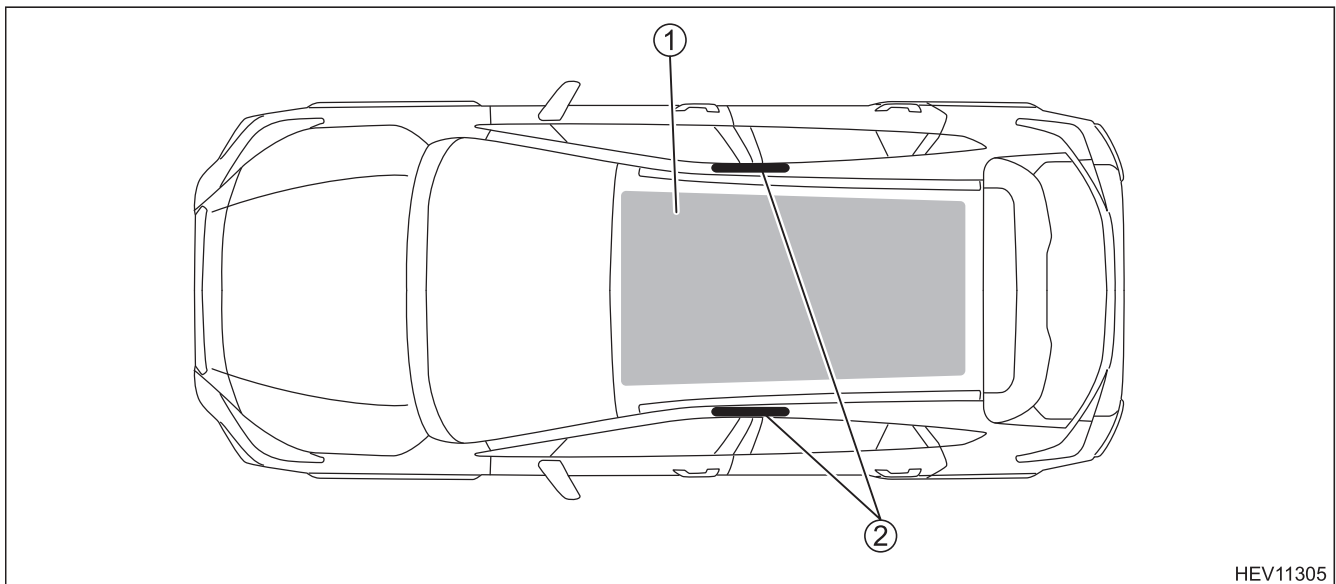

① Removal Area

② SRS Curtain Airbag Inflators

Emergency Response (Continued)

Repositioning Steering Wheel and Front Seat

Telescopic steering wheel and seat controls are shown in the illustrations.

Note:

The following operations of the power seat cannot be performed when the 12 Volt auxiliary battery is disconnected.

Head Restraint Removal

1. 1st position to the 3rd position Pull the head restraint up while pressing the release button on the top of the seatback.
2. While pressing the removal button using a key or other hard, pointed object, pull out the head restraint.

▼ Tilt and Telescoping Control

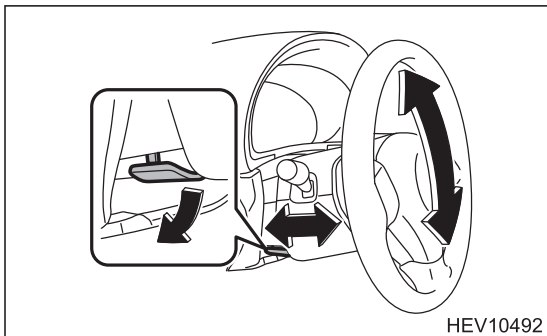

Emergency Response (Continued)

▼ Front Seat Controls

- Manual seat

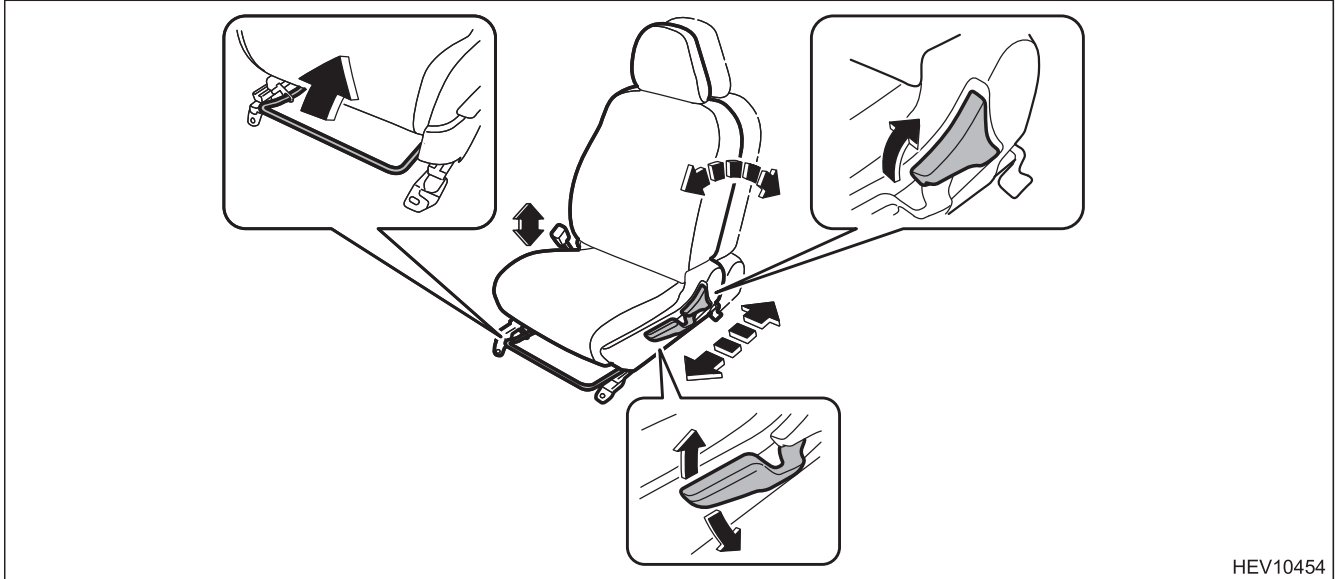

- Power seat

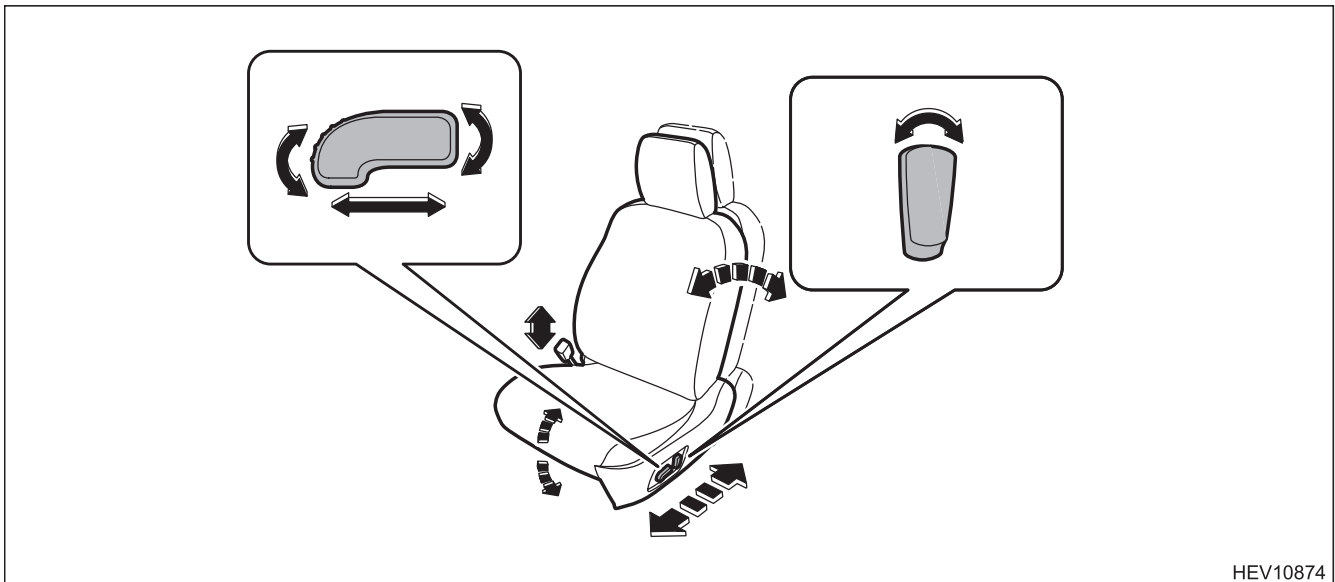

Emergency Response (Continued)

▼ Remove the Head Restraint

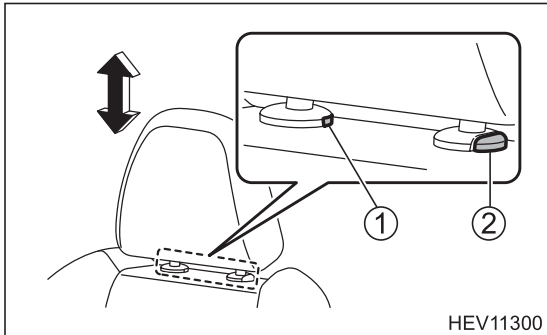

① Removal Button

② Release Button

Notes at the time of vehicle cutting

⚠ WARNING:

- Do not touch orange colored power cables, and high voltage parts to prevent serious injury and death from severe burns or electric shock. If you must touch them, you must wear insulated rubber gloves and insulate any exposed terminals or wires using an insulating tape.
- Only cut the vehicle using a hydraulic or sparkless cutter because serious injury or death to the rescuer and/or passenger could occur.
- If you must perform work on or near the SRS, please confirm that 60 seconds of elapsed has occurred after either the vehicle is shut off or the battery ground terminal of the 12 Volt auxiliary battery has been disconnected because the SRS airbag system may remain powered for up to 60 seconds.

Emergency Response (Continued)



Location where electrical shock by high voltage may occur.

Do not cut because of the risk of electrical shocks from high voltage.



Location where the curtain airbag may deploy.

Do not cut because there is equipment which generates high pressure gas for curtain airbag deployment in this location but if the curtain airbag has already deployed, it is possible to cut.



Location where the side airbag and the curtain airbag may deploy.

Do not cut in this area because the side airbag and curtain airbag may deploy by short circuit or impact. But if more than 60 seconds has elapsed since disconnecting the ground terminal of the 12V Auxiliary battery, it is OK to cut in this area.

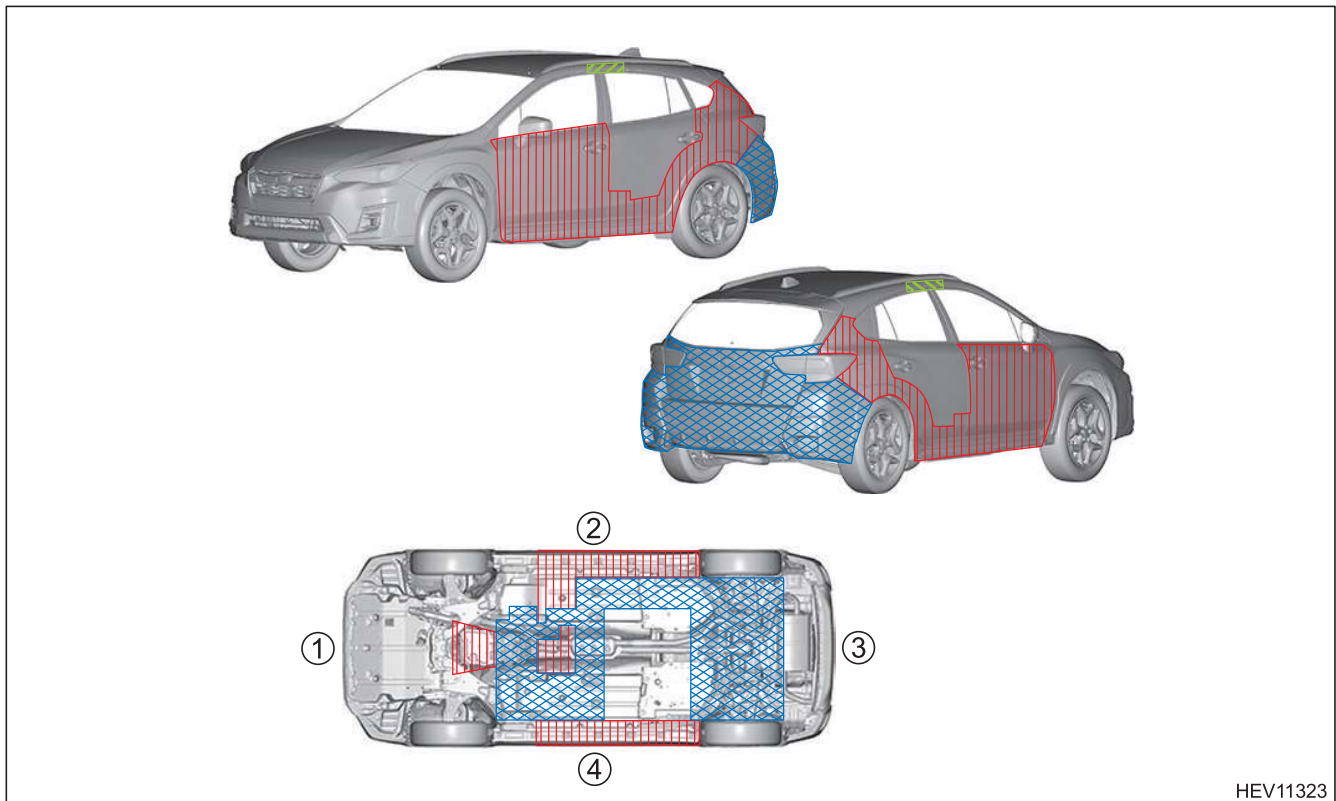

HEV11323

① Fr
② LH

③ Rr
④ RH

Fire

■ Extinguishing Agent

Water has been proven to be a suitable extinguishing agent.

■ Initial Fire Attack

Perform a fast, aggressive fire attack.

Divert the runoff to prevent it from entering watershed areas.

Attack teams may not be able to identify a IMPREZA e-BOXER/XV e-BOXER until the fire has been knocked down and overhaul operations have commenced.

■ Fire in the High Voltage Battery

Should a fire occur in the Li-ion high voltage battery, attack crews should utilize a water stream or fog pattern to extinguish any fire within the vehicle except for the high voltage battery.

WARNING:

- *Burning batteries may irritate the eyes, nose, and throat. To prevent injury wear personal protective equipment suitable for organic solvents including SCBA.*
- *The battery cells are contained within a metal case and accessibility is limited.*
- *To avoid serious injury or death from severe burns or electric shock, never breach or remove the high voltage battery assembly cover under any circumstance including fire.*

When allowed to burn themselves out, the IMPREZA e-BOXER/XV e-BOXER Li-ion battery cells burn rapidly and can quickly be reduced to ashes except for the metal component.

Offensive Fire Attack

Normally, flooding a Li-ion high voltage battery assembly with copious amounts of water at a safe distance will effectively control the high voltage battery assembly fire by cooling the adjacent Li-ion battery cells to a point below their ignition temperature. The remaining cells on fire, if not extinguished by the water, will burn themselves out.

However, flooding the IMPREZA e-BOXER/XV e-BOXER high voltage battery is not recommended due to the battery case design and location preventing the responder from properly applying water through the available vent openings safely. Therefore, it is recommended that the incident commander allow the IMPREZA e-BOXER/XV e-BOXER high voltage battery to burn itself out.

Defensive Fire Attack

If the decision has been made to fight the fire using a defensive attack, the fire attack crew should pull back a safe distance and allow the Li-ion battery cells to burn themselves out. During this defensive operation, fire crews may utilize a water stream or fog pattern to protect exposures or to control the path of smoke.

Overhaul

During overhaul, immobilize and disable the vehicle if not already done. Refer to illustrations on page 34. The high voltage battery cover should never be breached or removed under any circumstances including fire. Doing so may result in severe electrical burns, shock, or electrocution.

■ Immobilize Vehicle

Chock wheels and set the parking brake.
Shift the select lever to the park position.

■ Disable Vehicle

Performing any one of the following three procedures will shut the vehicle off and disable the high voltage battery, SRS, and gasoline fuel pump.

Procedure #1

Mechanical Ignition Key System (Standard Equipment):

Note:

Before shutting off the vehicle and disconnecting the 12 Volt auxiliary battery, if necessary, lower the windows, unlock the doors and open the rear gate as required. Once the 12 Volt auxiliary battery is disconnected, power controls will not operate.

1. Confirm the status of the HYBRID system READY indicator light in the combination meter.
2. If the HYBRID system READY indicator light is illuminated, the vehicle is on and operational. Shut off the vehicle by turning the ignition key off, removing the ignition key and placing it on the dash.

Note:

If the ignition switch will not move from the "LOCK" (off) position to the "ACC" position, turn the steering wheel slightly to the left and right as you turn the ignition switch.

3. Open the hood.
4. Disconnect the battery ground terminal of both the 12 Volt auxiliary battery and the 12 Volt engine restart battery in the engine compartment.

Keyless Access with Push-button Start System (Optional Equipment):

Note:

Before shutting off the vehicle and disconnecting the 12 Volt auxiliary battery, if necessary, lower the windows, unlock the doors and open the rear gate as required. Once the 12 Volt auxiliary battery is disconnected, power controls will not operate.

1. Confirm the status of the HYBRID system READY indicator light in the combination meter.
2. If the HYBRID system READY indicator light is illuminated, the vehicle is on and operational. Shut off the vehicle by pushing the push-button ignition switch once.
3. The vehicle is already shut off if the combination meter lights and the HYBRID system READY indicator light are not illuminated. Do not push the push-button ignition switch because the vehicle may start.
4. If the access key fob is easily accessible, keep it at least 5 meters (16 feet) away from the vehicle.
5. Open the hood.
6. Disconnect the battery ground terminal of both the 12 Volt auxiliary battery and the 12 Volt engine restart battery in the engine compartment.

Emergency Response (Continued)

Procedure #2 (Alternate if push-button ignition switch or ignition key is inaccessible)

Note:

Before shutting off the vehicle and disconnecting the 12 Volt auxiliary battery, if necessary, lower the windows, unlock the doors and open the rear gate as required. Once the 12 Volt auxiliary battery is disconnected, power controls will not operate.

1. Open the hood.
2. Remove the fuse box cover.
3. Remove the SBF No.4 fuse (30 A) in the engine compartment fuse box as illustrated on page 42. If the correct fuse cannot be recognized, pull all fuses in the fuse box.
4. Disconnect the battery ground terminal of the 12 Volt auxiliary battery and the 12 Volt engine restart battery in the engine compartment.

Procedure #3 (If procedures 1 and 2 cannot be implemented and insulated rubber gloves can be used)

Note:

Before shutting off the vehicle and disconnecting the 12 Volt auxiliary battery, if necessary, lower the windows, unlock the doors and open the rear gate as required. Once the 12 Volt auxiliary battery is disconnected, power controls will not operate.

1. Open the rear gate and remove the cargo area cover.
2. Unscrew the bolt and remove the service disconnect plug cover.
3. Wear insulated rubber gloves and then remove the service disconnect plug.
 - (1) Slide the lever toward rear of vehicle.
 - (2) Raise the lever until it is vertical.
 - (3) Pull the lever upward and remove the service disconnect plug from the high voltage battery holder.
4. Open the hood.
5. Disconnect the battery ground terminal of both the 12 Volt Auxiliary Battery and the 12 Volt Engine Restart Battery in the engine compartment.

WARNING:

- You must wear insulated rubber gloves to prevent serious injury or death from severe burns or electric shock.
- Be sure to carry the service disconnect plug on your person after you remove it to prevent another person from re-connecting it by mistake.
- The high voltage system may remain powered for up to 10 minutes after the vehicle is shut off or disabled. To prevent serious injury or death from severe burns or electric shock, avoid touching, cutting, or breaching any orange colored power cable or high voltage component.
- Before touching any high voltage parts, wiring, terminals or connector after the service disconnect plug has been removed, wait more than 10 minutes for the high voltage charge in the capacitor to discharge.
- The SRS may remain powered for up to 60 seconds after the vehicle is shut off or disabled. To prevent serious injury or death from unintentional SRS deployment, avoid breaching the SRS components.
- If none of the disabling procedures can be performed, proceed with caution as there is no assurance that the high voltage electrical system, SRS, or fuel pump are disabled.

Emergency Response (Continued)

Spills

The IMPREZA e-BOXER/XV e-BOXER contains the same common automotive fluids used in other non-hybrid SUBARU vehicles, with the exception of the Li-ion electrolyte used in the high voltage battery. The electrolyte used in the Li-ion battery cells is a flammable organic electrolyte. The electrolyte is absorbed into the battery cell separators, even if the battery cells are crushed or cracked, it is unlikely that liquid electrolyte will leak. Any liquid electrolyte that leaks from a Li-ion battery cell quickly evaporates.

WARNING:

- *The Li-ion battery contains organic electrolyte. Only a small amount may leak from the batteries which may irritate the eyes, nose, throat, and skin.*
- *Contact with the acidic vapor caused by the reaction of the electrolyte with moisture may irritate the nose and throat.*
- *To avoid injury by coming in contact with the electrolyte or acidic vapor, wear personal protective equipment for organic electrolyte including SCBA or protective mask for acidic vapors.*

Handle Li-ion electrolyte spills require using the following Personal Protective Equipment (PPE):

Splash shield or safety goggles. Fold down helmet shields are not acceptable for acid or electrolyte spills.

Rubber gloves or gloves suitable for organic solvents.

Apron suitable for organic solvents.

Rubber boots or boots suitable for organic solvents.

Protective mask for acidic vapors or SCBA.

Absorbent:

Suitable absorbent for an organic solvent.

First Aid

Emergency responders may not be familiar with a Li-ion electrolyte exposure when rendering aid to a patient. Exposure to the electrolyte is unlikely except in a catastrophic crash or through improper handling. Utilize the following guidelines in the event of exposure.

■ **Wear Personal Protective Equipment (PPE)**

Splash shield or safety goggles. Fold down helmet shields are not acceptable for acid or electrolyte spills.

Rubber gloves or gloves suitable for organic solvents.

Apron suitable for organic solvents.

Rubber boots or boots suitable for organic solvents.

Protective mask for acidic vapors or SCBA.

■ **Absorption**

Perform gross decontamination by removing affected clothing and properly disposing of the garments.

Rinse the affected areas with water for 20 minutes.

Transport patients to the nearest emergency medical care facility.

■ **Inhalation in Non-Fire Situations**

Contact with the acidic vapor caused by reaction of the electrolyte with moisture may irritate the nose and throat. In severe cases such as confined spaces, move exposed patients to a well ventilated area.

Transport patients to the nearest emergency medical care facility.

■ **Inhalation in Fire Situations**

Toxic gases are given off as by-products of combustion. All responders in the Hot Zone should wear the proper PPE for fire fighting including SCBA.

Move a patient from the hazardous environment to a safe area and administer oxygen.

Transport patients to the nearest emergency medical care facility.

■ **Ingestion**

Do not induce vomiting, unless instructed by the doctor.

If vomiting occurs naturally, avoid aspiration.

Transport patients to the nearest emergency medical care facility.

Submersion

Do not touch the service disconnect plug, high voltage parts and wiring to prevent electric shock when the vehicle is submerged.

Please shut off the hybrid system using the “Emergency Response” procedure beginning on page 34 after completely pulling the vehicle out of the water.

■ Access Patients

Use the “Emergency Response” procedure beginning on page 34 to stabilize the vehicle and shut off the hybrid system and then perform a rescue operation.

■ Vehicle Recovery

If a hybrid vehicle is fully or partially submerged in water, emergency responders may not be able to determine if the vehicle has been automatically disabled. Orange colored power cables, service disconnect plug and high voltage components should never be touched, cut or breached. The IMPREZA e-BOXER/XV e-BOXER may be handled by following these recommendations:

1. Remove the vehicle from the water.
2. Drain the water from the vehicle if possible.
3. Follow the immobilizing and disabling procedures on page 34.

Roadside Assistance

Roadside assistance for the SUBARU IMPREZA e-BOXER/XV e-BOXER may be handled like conventional SUBARU vehicles except as noted in the following pages.

Select Lever

- Similar to many SUBARU vehicles, the IMPREZA e-BOXER/XV e-BOXER uses a select lever as shown in the illustration.
- If the 12 Volt auxiliary battery is dead or the battery ground terminal of the 12 Volt auxiliary battery has been disconnected, the select lever cannot be moved out of the Park position.
- If the select lever cannot be moved out of Park position, a shift lock release button is provided under the cover near the select lever as shown in the illustration.
- Unlock the shift lock with the brake pedal depressed.

▼ Remove the Cover

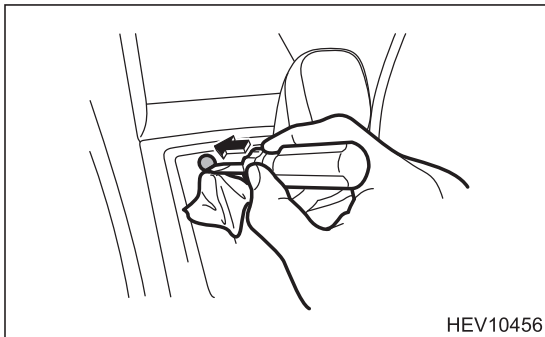

▼ Push in Shift Lock Release

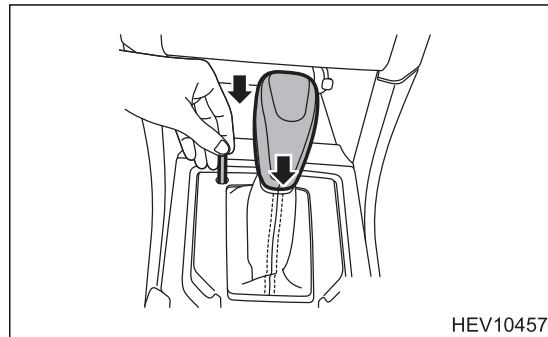

Steering Lock

For models with “keyless access with push-button start system”:

- If the 12 Volt auxiliary battery is dead, the steering lock touch sensitive release is cancelled. After jump starting the 12 Volt auxiliary battery in the engine compartment, you can cancel the steering lock by touching the steering wheel. See the instructions and illustrations on page 69 for more details.
- If the operation indicator is flashing in green, the hybrid system start procedure was performed, but the steering is still locked. While turning the steering wheel right and left slightly, depress the brake pedal and push the push-button ignition switch.

▼ Operation Indicator

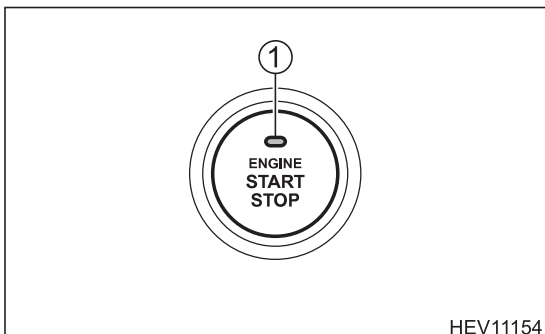

① Operation Indicator

Roadside Assistance (Continued)

Towing

If towing is necessary, it is best done by SUBARU dealer or a commercial towing service. Observe the following procedures for safety.

WARNING:

Never tow AWD models with the front wheels raised off the ground while the rear wheels are on the ground, or with the rear wheels raised off the ground while the front wheels are on the ground. This will cause the vehicle to spin away due to the operation or deterioration of the center differential.

■ Towing hook and tie-down hooks/holes

The towing hooks should be used only in an emergency (e.g., to free a stuck vehicle from mud, sand or snow).

Note:

- Use only the specified towing hook and tie-down hook. Never use suspension parts or other parts of the body for towing or tie-down purposes.
- To prevent deformation to the bumper and the towing hook, do not apply excessive load to the towing hook.

▼ Prohibited Methods

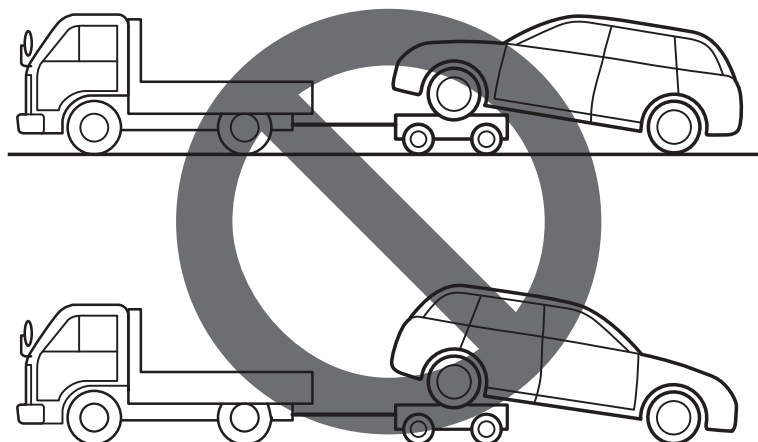

HEV10493

Roadside Assistance (Continued)

Front towing hook:

1. Take the towing hook and screwdriver out of the tool bucket.
Take out the jack handle and wheel nut wrench from under the left side front seat.
2. Cover the tip of a flat-head screwdriver with vinyl tape or cloth so that it will not scratch the bumper. Insert the flat-head screwdriver into the cutout of the cover and pry open the cover.
3. Screw the towing hook into the thread hole until its thread can no longer be seen.
4. Tighten the towing hook securely using the jack handle and wheel nut wrench.
After towing, remove the towing hook from the vehicle and return it to its storage position.
Fit the towing hook cover on the bumper.

WARNING:

- Do not use the towing hook except when towing your vehicle.
- Be sure to remove the towing hook after towing. Leaving the towing hook mounted on the vehicle could interfere with proper operation of the SRS airbag system in a frontal collision.

▼ Front Towing Hook Cover

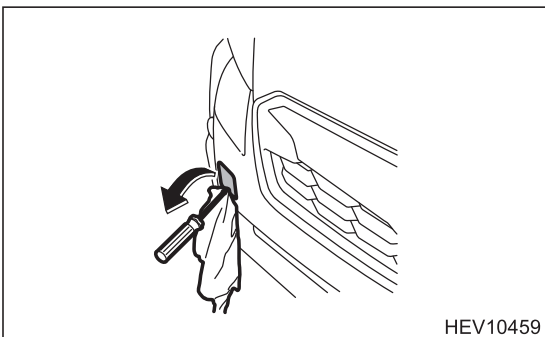

▼ Front Towing Hook Mounting Location

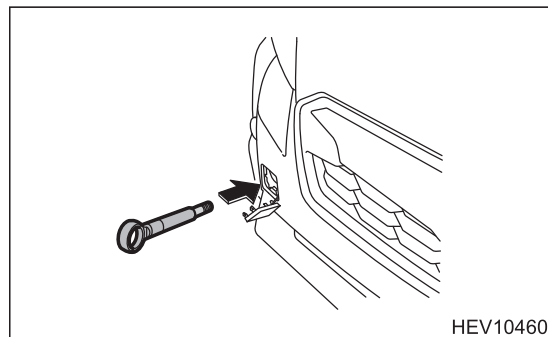

▼ Front Towing Hook Installation

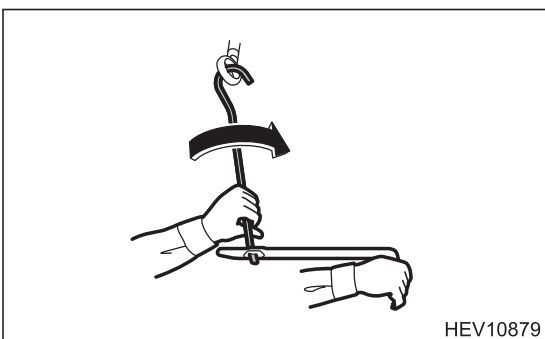

Roadside Assistance (Continued)

Rear towing hook:

1. Take the towing hook and screwdriver out of the tool bucket.
Take out the jack handle and wheel nut wrench from under the left side front seat.
2. Cover the tip of a flat-head screwdriver with vinyl tape or cloth so that it will not scratch the bumper. Pry off the cover on the rear bumper using a screwdriver, and you will find a threaded hole for attaching the towing hook.
3. Screw the towing hook into the threaded hole until its thread can no longer be seen.
4. Tighten the towing hook securely using the jack handle and wheel nut wrench.
After towing, remove the towing hook from the vehicle and return it to its storage position.
Fit the towing hook cover on the bumper.

WARNING:

- Do not use the towing hook except when towing your vehicle.
- Be sure to remove the towing hook after towing. Leaving the towing hook mounted on the vehicle could interfere with proper operation of the fuel pump shut off function when the vehicle is struck from behind.

▼ Rear Towing Hook Cover

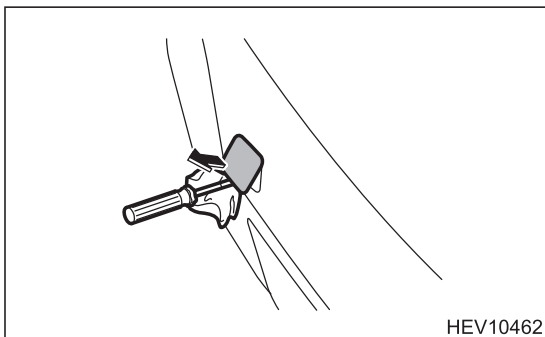

▼ Rear Towing Hook Mounting Location

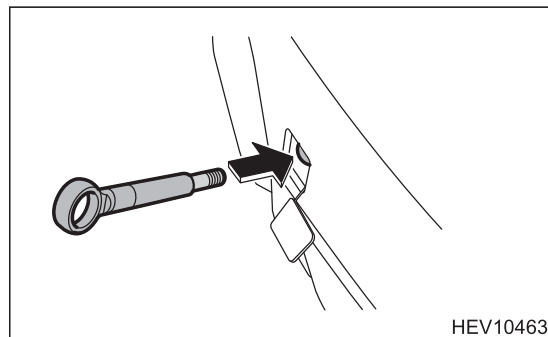

▼ Rear Towing Hook Installation

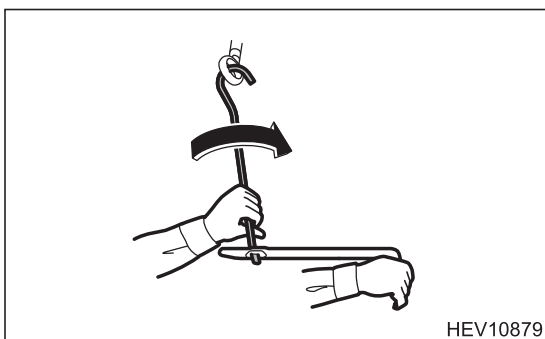

Roadside Assistance (Continued)

Front tie-down hooks:

The front tie-down hooks are located between each of the front tires and the front bumper.

Rear tie-down holes:

The rear tie-down holes are located near each of the jack-up reinforcements.

There is a plug in each rear tie-down hole. To use the rear tie-down holes, remove the plugs. After using the rear tie-down holes, return the plugs to their original places.

WARNING:

Use the rear tie-down holes only for downward anchoring. If they are used to anchor the vehicle in any other direction, cables may slip out of the holes, possibly causing a dangerous situation.

▼ Front Tie-down Hooks

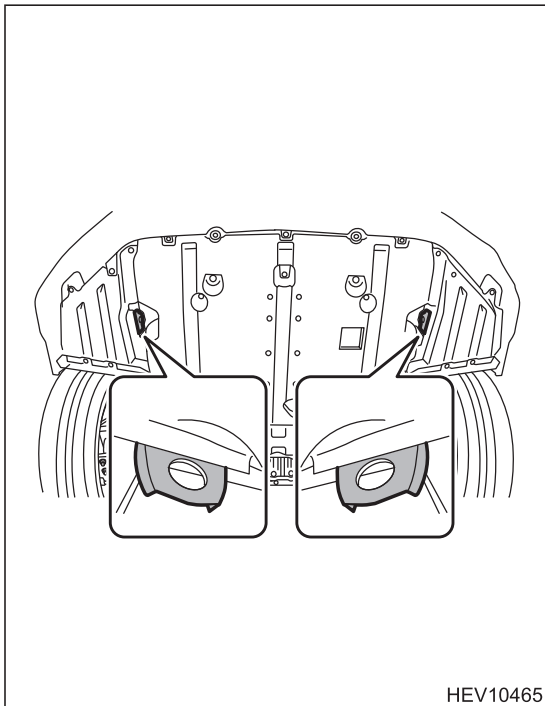

▼ Rear Tie-down Holes

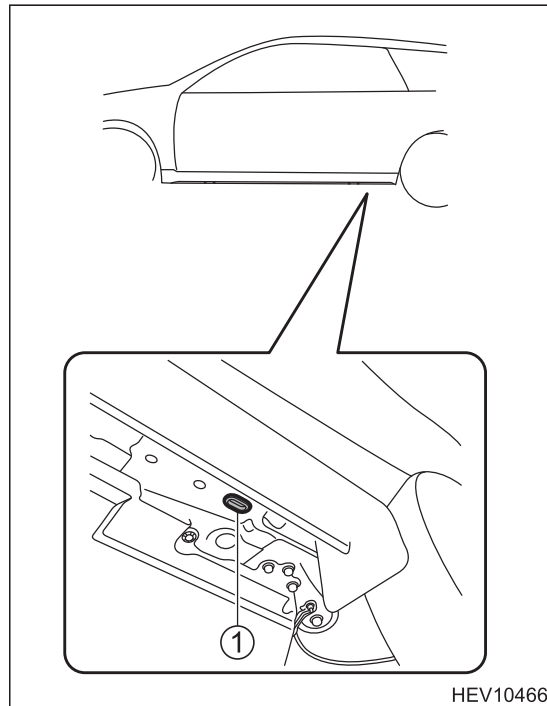

① Rear Tie-down Holes

Roadside Assistance (Continued)

■ Using a flat-bed truck

This is the best way to transport the vehicle. Use the following procedures to ensure safe transportation.

1. Shift the select lever into the Park position.
2. Apply the parking brake.
3. Secure the vehicle onto the carrier properly with safety chains. Each safety chain should be equally tightened and care must be taken not to pull the chains so tightly that the suspension bottoms out.

Note:

If the vehicle has a front underspoiler and rear underspoiler (both optional), be careful not to scrape them when placing the vehicle on the carrier and when removing the vehicle from the carrier.

▼ Using a Flat-bed Truck

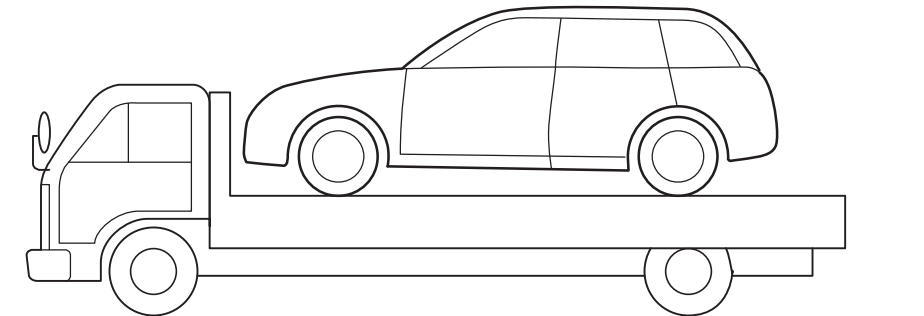

HEV10494

CAUTION:

- If your vehicle has a bumper under guard (optional), be careful not to scrape it when placing the vehicle on the carrier and when removing the vehicle from the carrier.
- Transport by flat-bed truck may cause the headlights to become misaligned. In such a case, have the headlight alignment checked by a SUBARU dealer after transporting the vehicle by flat-bed truck.

Roadside Assistance (Continued)

■ Towing with all wheels on the ground

1. Release the parking brake and shift the select lever to the Neutral position.
2. The ignition switch or push-button ignition switch should be in the "ACC" position while the vehicle is being towed.
3. Take up slack in the towline slowly to prevent damage to the vehicle.

WARNING:

- If having to tow the vehicle with a rope and all wheels on the ground, install a towing hook on the towing hook attachment of the front bumper and secure a soft rope to the towing hook.
- If there is a long or steep downhill along the tow route, ask roadside assistance to tow the vehicle with all wheels off the ground.
- The engine brake is totally disabled while towing with a rope, therefore, if the brake pedal is kept pressed while going downhill, the brake may overheat and disable as well.
- Drive the towing vehicle so as not to jerk the rope by sudden acceleration or the like.
- Some vehicles cannot be towed depending on the cause of the trouble.
- Never turn the ignition switch to the "LOCK" (off) position or push the push-button ignition switch to the "OFF" position while the vehicle is being towed because the steering wheel and the direction of the wheels will be locked.
- Remember that the brake booster and power steering do not function when the hybrid system is not running. Because the hybrid system is turned off, it will take greater effort to operate the brake pedal and steering wheel.
- When towing a vehicle equipped with SUBARU EyeSight, be sure to hold down the pre-collision brake OFF switch to turn the pre-collision braking OFF. (Confirm that the pre-collision brake OFF indicator in the meter has lit up.)

Note:

- If transmission failure occurs, transport the vehicle on a flat-bed truck.
- Do not run the HYBRID system while being towed using this method. Transmission damage could result if the vehicle is towed with the HYBRID system running.
- The traveling speed must be limited to less than 30 km/h (19 mph) and the traveling distance to less than 50 km (31 miles). For greater speeds and distances, transport the vehicle on a flat-bed truck.

▼ Towing with All Wheels on the Ground

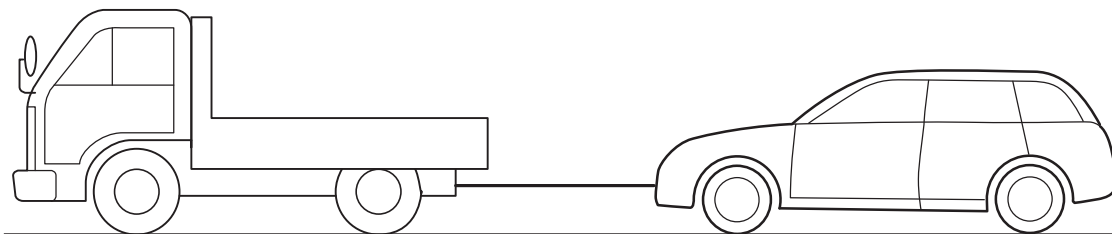

HEV10495

Rear Gate

In the event that you cannot open the rear gate by operating the rear gate opener button, you can open it from inside the cargo area.

1. Remove the access cover at the bottom-center of the rear gate trim.
2. Locate the rear gate open lever behind the rear gate trim panel. Never operate the rear gate open lever with fingers because doing so may cause an injury. Always use a flat blade screwdriver or similar tool.
3. To open the rear gate, move the lever to the right using the flat blade screwdriver or similar tool.

▼ Remove the Access Cover

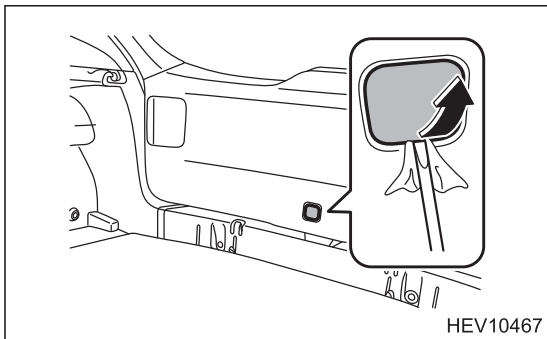

▼ Turn the Lever

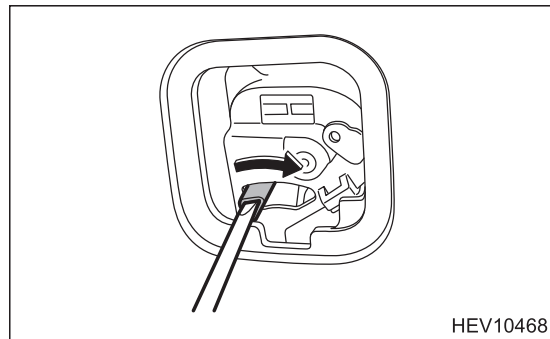

Maintenance Tools

The IMPREZA e-BOXER/XV e-BOXER is equipped with the following maintenance tools.

- Flat tire repair kit
- Jack
- Jack handle
- Screwdriver
- Towing hook (eye bolt)
- Wheel nut wrench

▼ Tool Locations

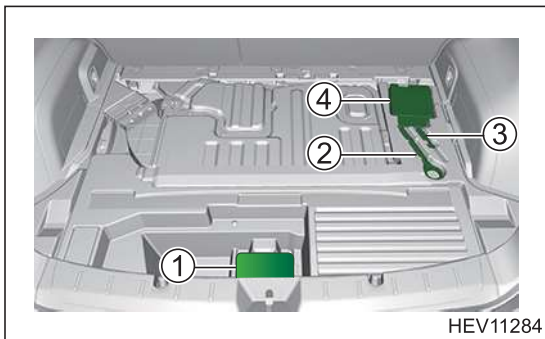

- ① Flat tire repair kit (sealant bottle)
- ② Towing hook (eye bolt)
- ③ Screwdriver
- ④ Flat tire repair kit (plastic bag)

▼ To Take Out the Tools

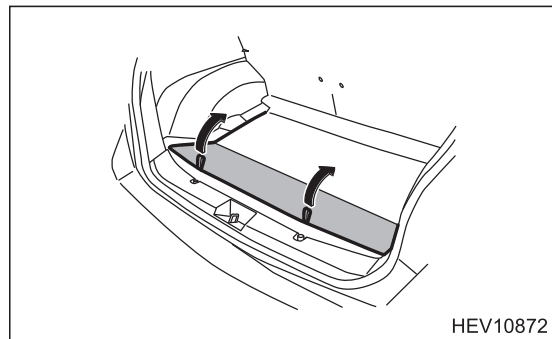

▼ Tool Locations

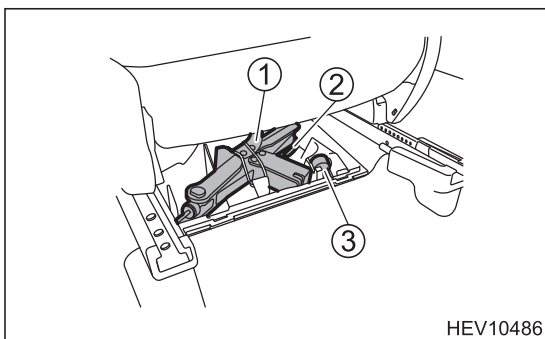

- ① Jack
- ② Jack handle
- ③ Wheel nut wrench

▼ To Take Out the Tools

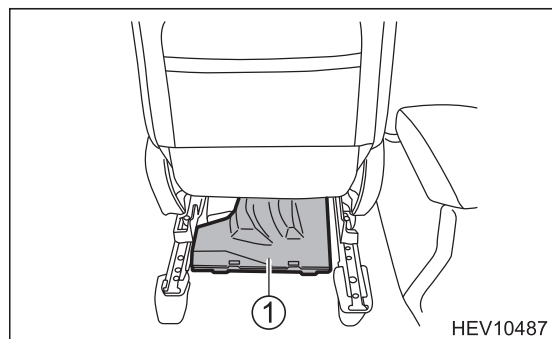

- ① Open the lid under the left side front seat.

Jump Starting

The 12 Volt auxiliary battery may be jump started if the vehicle does not start and the combination meter is dim or off after depressing the brake pedal and pushing the push-button ignition switch or turning the ignition switch.

The 12 Volt auxiliary battery is located in the driver side of the engine compartment.
(Left-hand drive models)

The 12 Volt auxiliary battery is located in the passenger side of the engine compartment.
(Right-hand drive models)

WARNING:

- Do not connect the jumper cable to the 12 Volt engine restart battery.
- Never connect jumper cables between the 12 Volt engine restart battery and the 12 Volt auxiliary battery.

▼ 12 Volt Auxiliary Battery

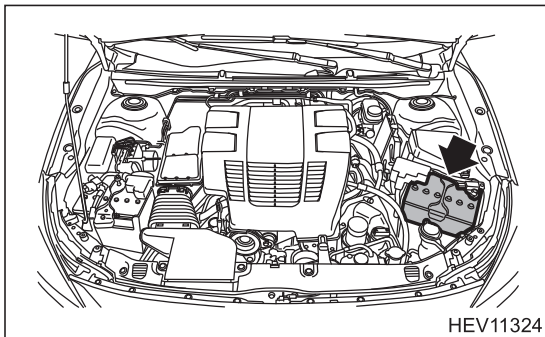

HEV11324

▼ 12 Volt engine restart battery

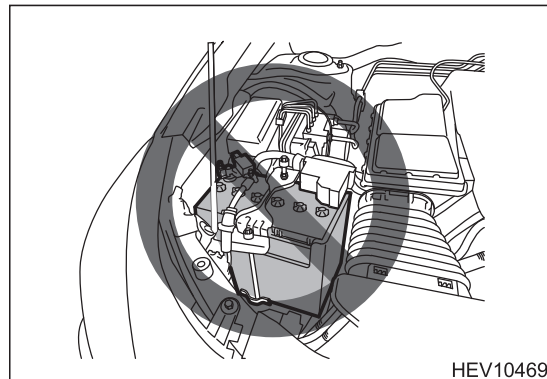

HEV10469

■ Jump Starting a Dead 12 Volt Auxiliary Battery

1. Make sure the booster battery is 12 Volts and the negative terminal is grounded.
2. If the booster battery is in another vehicle, do not let the two vehicles touch.
3. Turn off all unnecessary lights and accessories.
4. Connect the jumper cables exactly in the sequence described:
 - ① Connect one jumper cable to the positive (+) terminal on the 12 Volt auxiliary battery.
 - ② Connect the other end of the jumper cable to the positive (+) terminal of the booster battery.
 - ③ Connect one end of the other cable to the negative (-) terminal of the booster battery.
 - ④ Connect the other end of the cable to the strut mounting nut of the vehicle being jumped.
Make sure that the cables are not near any moving parts and that the cable clamps are not in contact with any other metal.
5. Start the engine of the vehicle with the booster battery and run it at moderate speed. Then start the hybrid system of the vehicle that has the discharged battery.
6. When finished, carefully disconnect the cables in exactly the reverse order.

▼ Jump Starting a Dead 12 Volt Auxiliary Battery

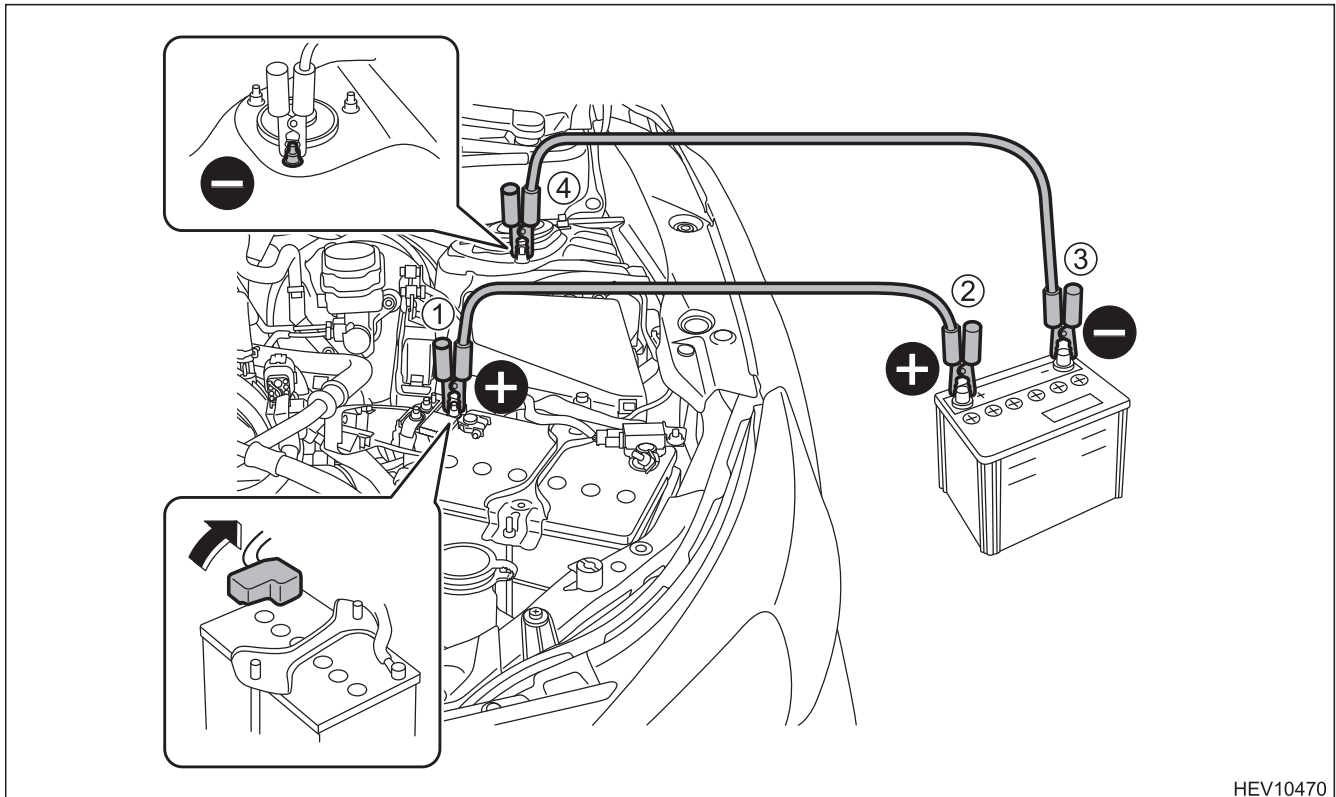

Roadside Assistance (Continued)

For models with “keyless access with push-button start system”:

After the 12 Volt auxiliary battery is discharged or replaced, initialization of the steering lock system may be required to start the hybrid system. In this case, perform the following procedure to initialize the steering lock.

- (1) Push the push-button ignition switch to the “OFF” position.
- (2) Open and close the driver’s door.
- (3) Wait for approximately 10 seconds.

When the steering is locked, the initialization is completed.